



# QUANTUM VALVE & TITAN II PLUS VALVE SELECTION GUIDE

Microelectronics Product Line

Catalog 4504/USA  
October 2003



# QUANTUM VALVE & TITAN II PLUS VALVE SELECTION GUIDE

Microelectronics Product Line

Catalog 4504/USA  
October 2003

## table of contents

Quantum Valve Selection Guide	
<i>Safe Valve Selection</i> . . . . .	1
<i>Selection Guide</i> . . . . .	1
<i>Flow Path</i> . . . . .	1
<i>Port Numbering/End Connections</i> . . . . .	2
<i>930/945 Dimension</i> . . . . .	2
<i>955 Dimension</i> . . . . .	3
<i>Quantum Valve Ordering Information</i> . . . . .	4
TITAN II® PLUS Valve Selection Guide	
<i>TITAN II PLUS Valve Selection Guide</i> . . . . .	5
<i>TITAN II PLUS Dimensional Drawings</i> . . . . .	6
<i>TITAN II PLUS Dimensional Drawings</i> . . . . .	7
<i>TITAN II PLUS Flow Curve</i> . . . . .	7
<i>TITAN II PLUS Ordering Information</i> . . . . .	8



**Parker Hannifin Corporation**  
Veriflo Division  
250 Canal Boulevard  
Richmond, CA 94804-0034  
Telephone 510.235.9590  
Fax 510.232.7396  
<http://www.veriflo.com>





## Safe Valve Selection

When selecting a valve, the total system design must be considered to ensure safe, trouble-free performance. Valve function, material compatibility, adequate ratings, proper installation, operation, and maintenance are the responsibility of the system designer and end-user.

## Selection Guide

Customize a valve to meet your system requirements. Your choice of Valve Actuation, End Connections and Flow Path are described in this section. The model designation options start with selection of the actuator in Figure #1.

**Valve Actuation - Figure #1**

Actuator Style	Pressure Range Vacuum to...	Description of Actuator	Actuator Designator
Manual 930,955 917 945	250 psig (17 barg) 3000 psig (207 barg) <sup>1</sup> 3500 psig (240 barg) <sup>1</sup>	Round handwheel 1/4 Turn Lever Indicating Handwheel Mini 1/4 turn lever	S L I M
Pneumatic (low pressure)	125 psig (8.6 barg)	Normally Closed <sup>2</sup> Normally Open <sup>2</sup>	AOPLP1NC <sup>4</sup> AOPLPNC AOPLP1NO <sup>4</sup> AOPLPNO
Pneumatic (high pressure)	3500 psig (240 barg) <sup>1</sup>	Normally Closed <sup>2</sup>	AOPHPNC <sup>3</sup> AOPHP1NC <sup>3,4</sup>

1. For oxygen: 2200 psig (150 bar) • 2. Actuation pressure - 75 psig nominal (60-120 psig) • 3. 945 Only  
• 4. "1" Designates Integral Cartridge Fitting for 1/8" O.D. Plastic Tube.

Note: Use 930 or 945 to replace 944 valves

## Flow Path

Select a body configuration with the desired internal flow path in Figure #2. The flow path is shown as viewed from the top of the body.

**Flow Path Designator - Figure #2**

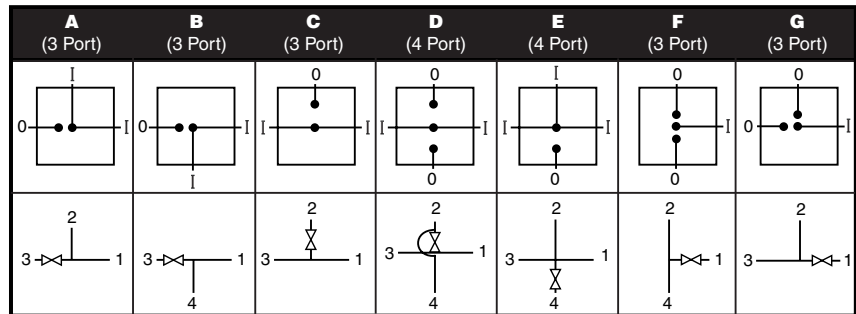

Although high purity valves will operate in either flow direction, the "O" port is generally used as the outlet or downstream port and the "I" port is normally used as the inlet or upstream port. The Flow Path Designator letter will be used in the Valve Ordering Information.

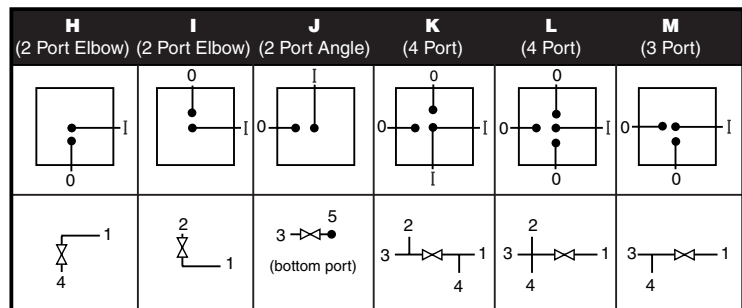

## Port Numbering/ End Connections

Starting with Port 1 and continuing in numerical sequence with Ports 2, 3, 4, and 5 as shown in Figure #3, select a designator for each port that will be used, i.e. two designators for a two port body, three designators for a three port body, and so on, even if the connections are identical. Select the desired End Connection using the End Connection Style Chart (Figure #4) for each port on the body.

**Figure #3**

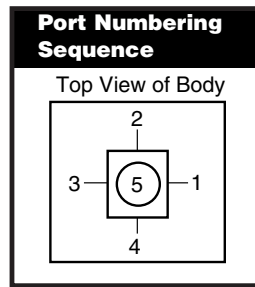

5 = bottom port

**Figure #4**

End Connection Size/Style	Designator
1/4" Tube Stub (.250 x .035)	1
1/4" Face Seal Male Swivel	2
1/4" Face Seal Female Swivel	3
3/8" Tube Stub (.375 x .035)	4
1/2" Face Seal Male Swivel	5
1/2" Face Seal Female Swivel	6
1/2" Tube Stub (.500 x .049)	7
1/8" Tube Stub* (.125 x .028)	A1
1/8" Face Seal Male*	A2
1/8" Face Seal Female*	A3

\* 917 Series Only

## 930/945 Dimensions

Overall height and actuator dimensions are shown in Figure #7. Centerline to port dimensions are shown in Figure #8. Port to port dimensions are determined by adding the "A" dimensions together.

**Note:** All dimensions are in inches. For reference only.

**Figure #7 • 930/945 Series**

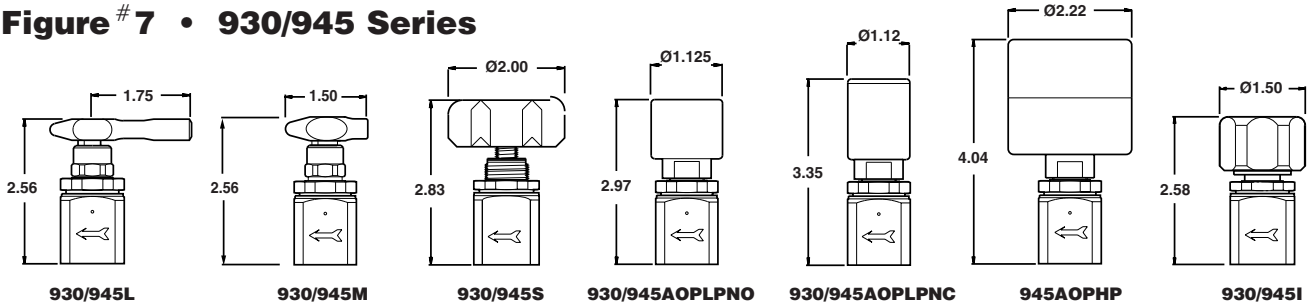

**Note:** Standard Lever And Handwheel Color Is Blue

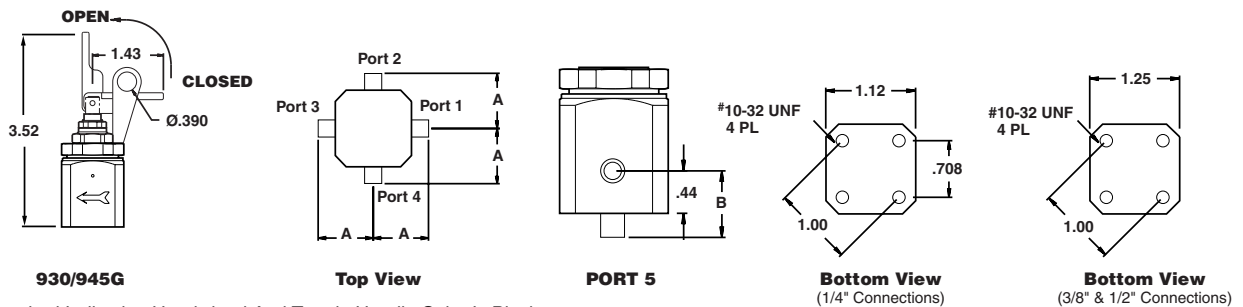

**Note:** Standard Indicating Handwheel And Toggle Handle Color Is Black

**Figure #8**

Standard Dimensions (inches)				Dimension Tolerance ± 0.03			
End Connection	A	B	Designator	End Connection	A	B	Designator
1/4" Tube Stub (.250 x .035)	0.875	0.69	1	3/8" Tube Stub (.375 x .035) <sup>1</sup>	1.12	.94	4
1/4" Face Seal Male Swivel (.347 O.D. Gland)	1.39	1.26	2	1/2" Face Seal Male Swivel <sup>1</sup>	2.07	1.89	5
1/4" Face Seal Female Swivel (.347 O.D. Gland)	1.39	1.26	3	1/2" Face Seal Female Swivel <sup>1</sup>	2.07	1.89	6
				1/2" Tube Stub (.500 x .049)	1.12	.94	7

1. 3/8" & 1/2" connections use 1.250" square body

## 955 Dimensions

Overall height and actuator dimensions are shown in Figure #9. Centerline to port dimensions are shown in Figure #10. Port to port dimensions are determined by adding the "A" dimensions together.

**Note:** All dimensions are in inches. For reference only.

**Figure # 9 • 955 Series**

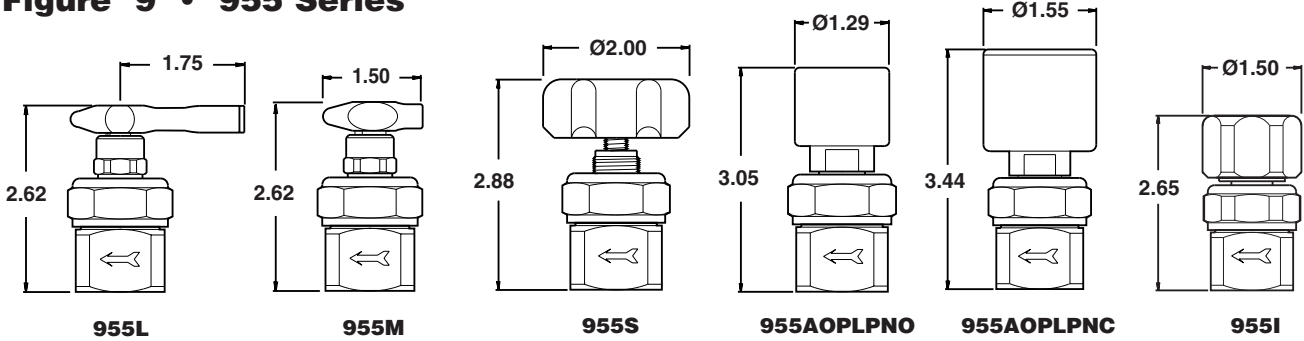

**Note:** Standard Lever And Handwheel Color Is Blue

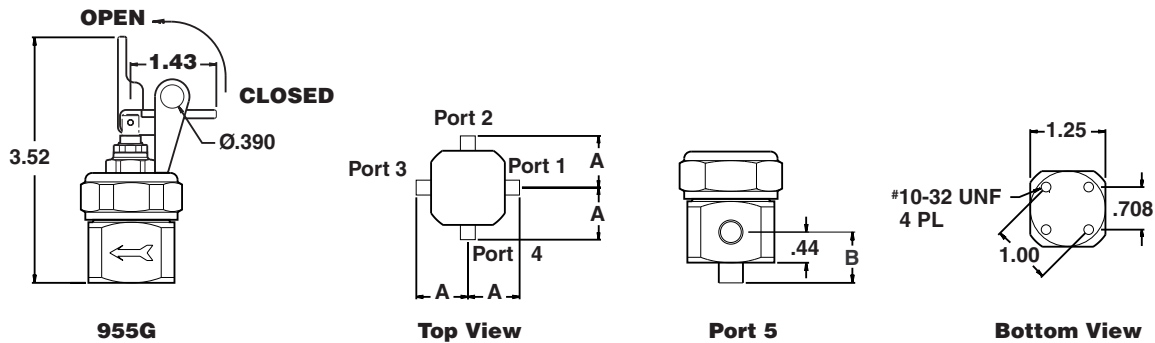

**Note:** Standard Indicating Handwheel And Toggle Handle Color Is Black

**Figure #10**

Standard Dimensions (inches)				Dimension Tolerance $\pm 0.03$			
End Connection	A	B	Designator	A	B	Designator	
1/4" Tube Stub (.250 x .035)	1.12	0.94	1	3/8" Tube Stub (.375 x .035)	1.12	.94	4
1/4" Face Seal Male Swivel (.347 O.D. Gland)	1.48	1.26	2	1/2" Face Seal Male Swivel	2.10	1.89	5
1/4" Face Seal Female Swivel (.347 O.D. Gland)	1.48	1.26	3	1/2" Face Seal Female Swivel	2.10	1.89	6
				1/2" Tube Stub (.500 x .049)	1.12	.94	7

## Ordering Information

Build or configure a valve to your specifications using the ordering information below. Complete the configuration by combining the modular designators in the sequence shown below.

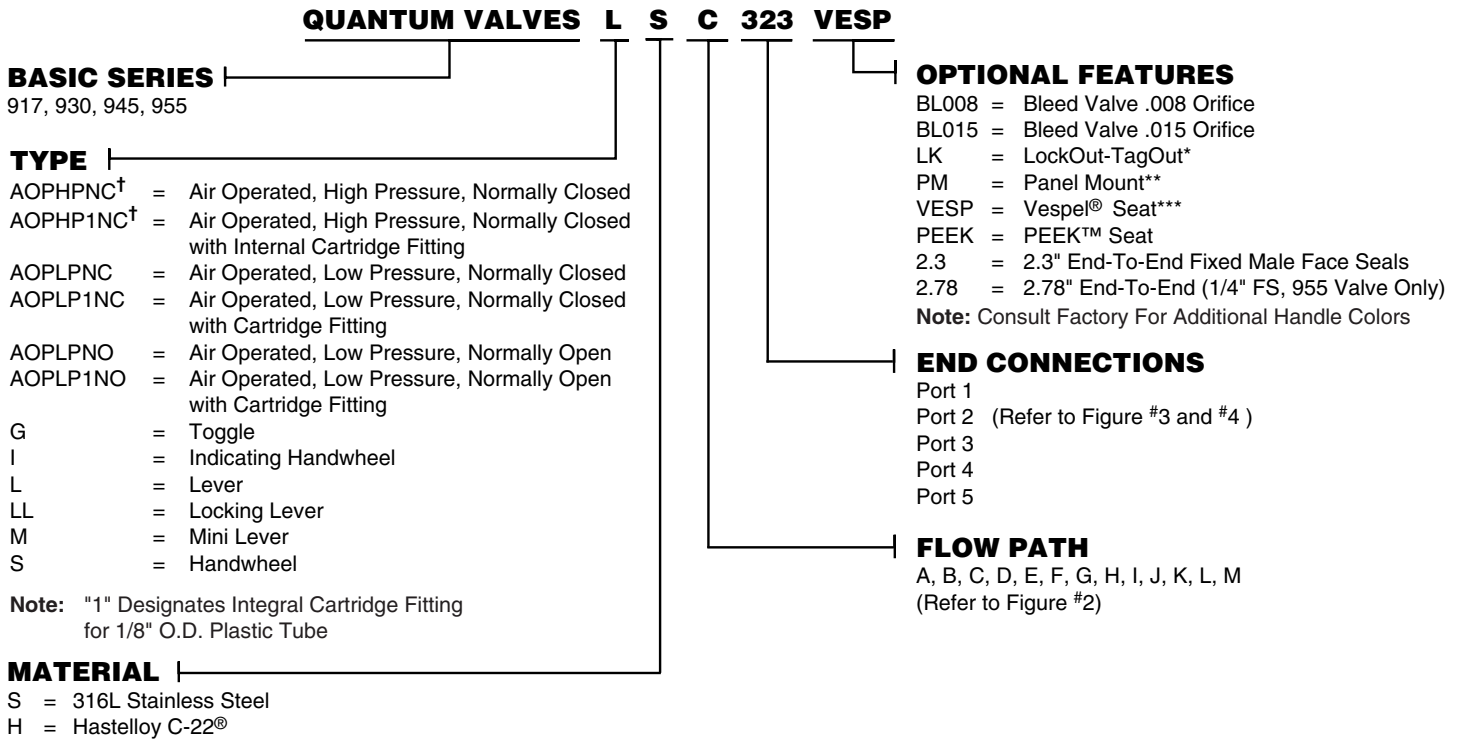

\* **LockOut-TagOut Clamp for M Type Valves**

**LockOut-TagOut Bracket for G Type Valves**

\*\* **Not available with Indicating Handwheel (I), or AOP types**

\*\*\* **Recommended for Nitrous Oxide (N<sub>2</sub>O) Service**

† **Available only with 945 Series.**

**Note:** 1/2" connectors are not available on the 917 Series

Hastelloy C-22® is a registered trademark of Haynes International, Inc.

Vespel® is a registered trademark of DuPont Company.

PEEK™ is a registered trademark of Victrex plc.



Parker Hannifin Corporation's Veriflo Division presents the TITAN II® Valve Selection Guide. The TITAN II® Springless Diaphragm Valves are specifically designed for high pressure, high cycle, ultra high purity applications.

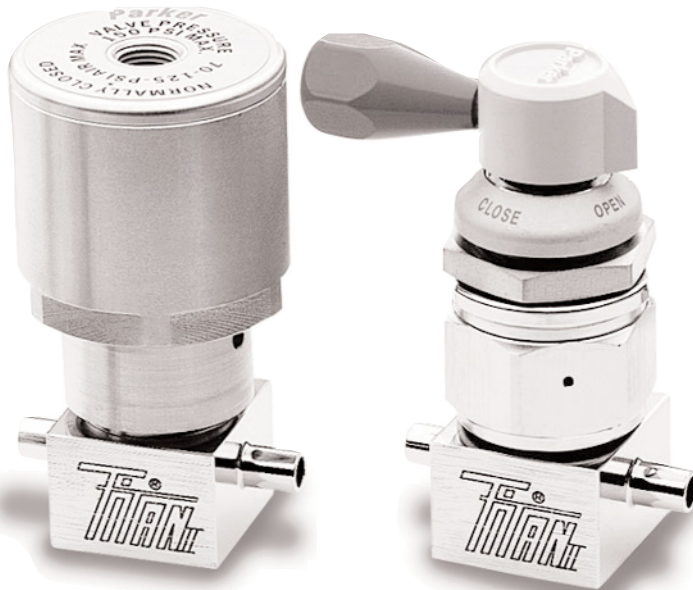

### features

- ▶ "VeriClean", Veriflo's custom high purity Type 316L Stainless Steel™
- ▶ Springless, stemless design.
- ▶ Metal diaphragm sealed.
- ▶ Back panel mounting capabilities.
- ▶ High cycle life.
- ▶ Fully swept flow path.
- ▶ Standard 6 micro inch Ra (0.15 micro meter), EP Surface Finish.
- ▶ 100% Helium leak tested.
- ▶ Reduced seat volume.

### materials of construction

#### Wetted

Body . . . . . "VeriClean", Veriflo's custom high purity Type 316L Stainless Steel™ optional Hastelloy C-22® or Nickel 200  
 Seat . . . . . PCTFE, optional Vespel®

#### Non-wetted

Bonnet . . . . . 303 Stainless Steel  
 Bonnet nut . . . . . 303 Stainless Steel

### operating conditions

Maximum operating pressure . . . . . 3000 psig (207 barg)  
 90 Series . . . . . 150 psig (10 barg)  
 92 Series . . . . . 300 psig (20.1 barg)

#### Temperature:

PCTFE Seat . . . . . -65°F to 150°F (-54°C to 65°C)  
 Vespel® Seat . . . . . -65°F to 250°F (-54°C to 121°C)

### functional performance

Flow Capacity . . . . .  $C_v$  0.25,  $X_T=0.51$

#### Design Leak Rate:

Outboard . . . . .  $1 \times 10^{-9}$  scc/sec He  
 Inboard . . . . .  $1 \times 10^{-9}$  scc/sec He  
 Across seat . . . . .  $1 \times 10^{-9}$  scc/sec He

### internal volume

1.55 cc

### surface finishes

Standard Ra . . . . . 6 micro inch Ra (0.15 micro meter) EP surface finish



### Dimensional Drawings

#### 06 + Series

1/2 & 1/4 Turn  
Round Handle

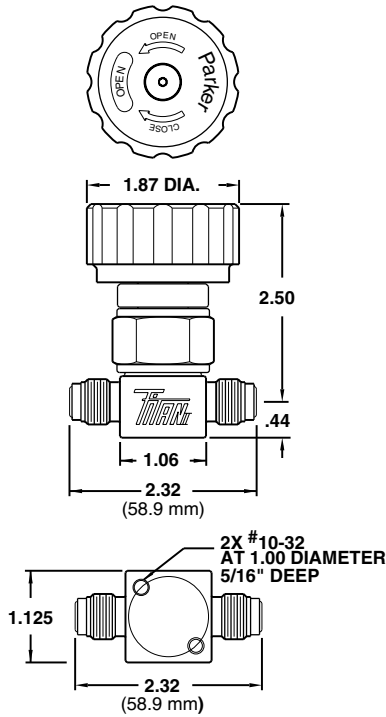

#### 07 + Series:

1/4 Turn Lever Handle

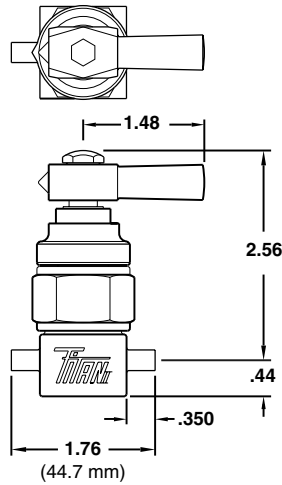

#### 07L + Series:

1/4 Turn Lever Indicator  
Positional Handle

PANEL MOUNTING:  
HOLE SIZE: .88-1.00"  
PANEL THICKNESS: 0.06"-0.37"

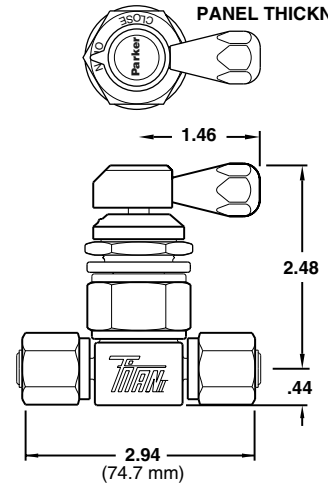

#### 90+06 Series:

Pneumatic 150 psig (10.5 bar)

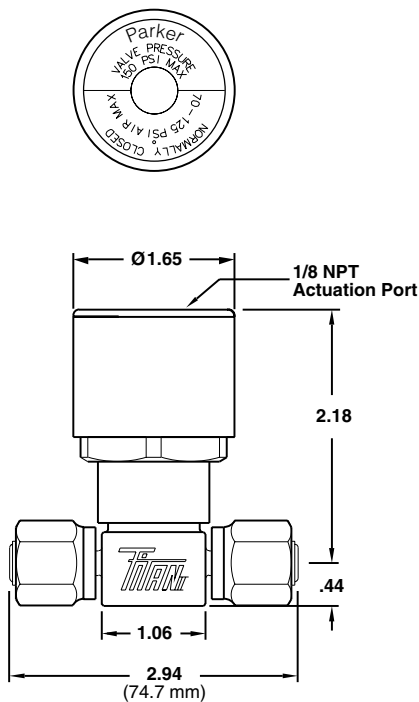

#### 92+06 Series:

Pneumatic 300 psig (20.7 barg)

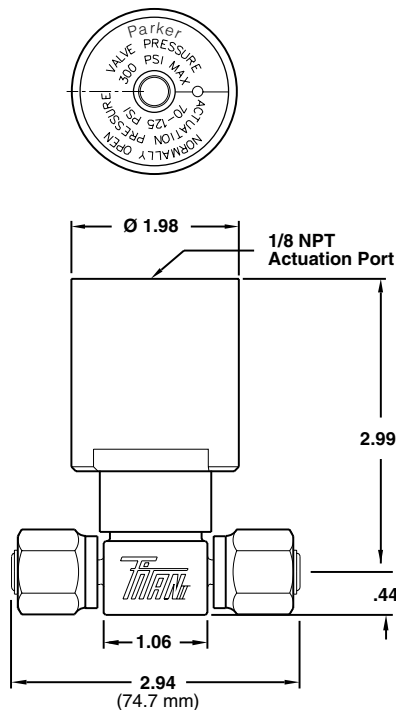

#### 94+06 Series:

Pneumatic 3000 psig (207 barg)

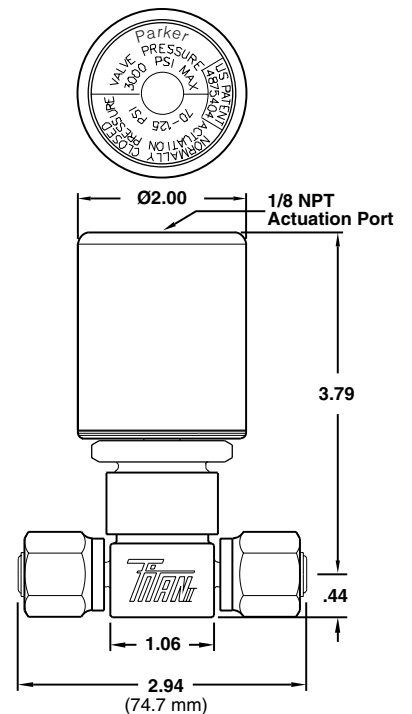



End Connections	Dimensions "A" Inches (mm)	Dimensions "B" Inches (mm)
1/4" Tube/weld (TW)	0.88 (22.4)	0.88 (22.4)
1/4" VacuSeal (VF)	1.47 (37.3)	1.36 (34.5)
1/4" VacuSeal (VM)	1.16 (29.5)	-
1/4" VacuSeal (VMS)	1.97(50.0)	1.62 (41.2)

Top View - Female VacuSeal

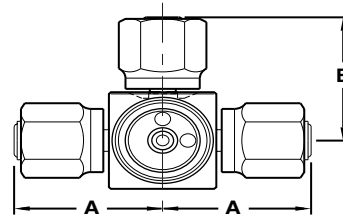

Dimensions are for reference only.

Part Number	Port Position 1	Port Position 2	Port Position 3	Port Position 4	Dimensions "A" Inches(mm)	Dimensions "B" Inches(mm)
07+4442TWTSITW	1/4" Inlet	1/4" Inlet	1/4" Outlet	None	0.88 (22.4)	0.88 (22.4)
07+4442TWXTWTWI	1/4" Inlet	None	1/4" Outlet	1/4" Inlet	0.88 (22.4)	0.88 (22.4)
06+44442TWTWITWTW-P	1/4" Inlet	1/4" Inlet	1/4" Outlet	1/4" Outlet	0.88 (22.4)	0.88 (22.4)
06+4442TWXTWTW	1/4" Inlet	None	1/4" Outlet	1/4" Outlet	0.88 (22.4)	0.88 (22.4)
06+4442VMSVMSVMSI	1/4" Inlet	1/4" Outlet	1/4" Inlet	None	1.97 (50.0)	1.62 (41.2)
94+0644442TWTWITWTW	1/4" Inlet	1/4" Inlet	1/4" Outlet	1/4" Outlet	0.88 (22.4)	0.88 (22.4)
07+4442VFVFVF	1/4" Inlet	1/4" Outlet	1/4" Outlet	None	1.47 (37.3)	1.36 (34.5)
92+06442TWXXTW	1/4" Inlet	None	None	1/4" Outlet	0.88 (22.4)	0.88 (22.4)

## Flow Curves

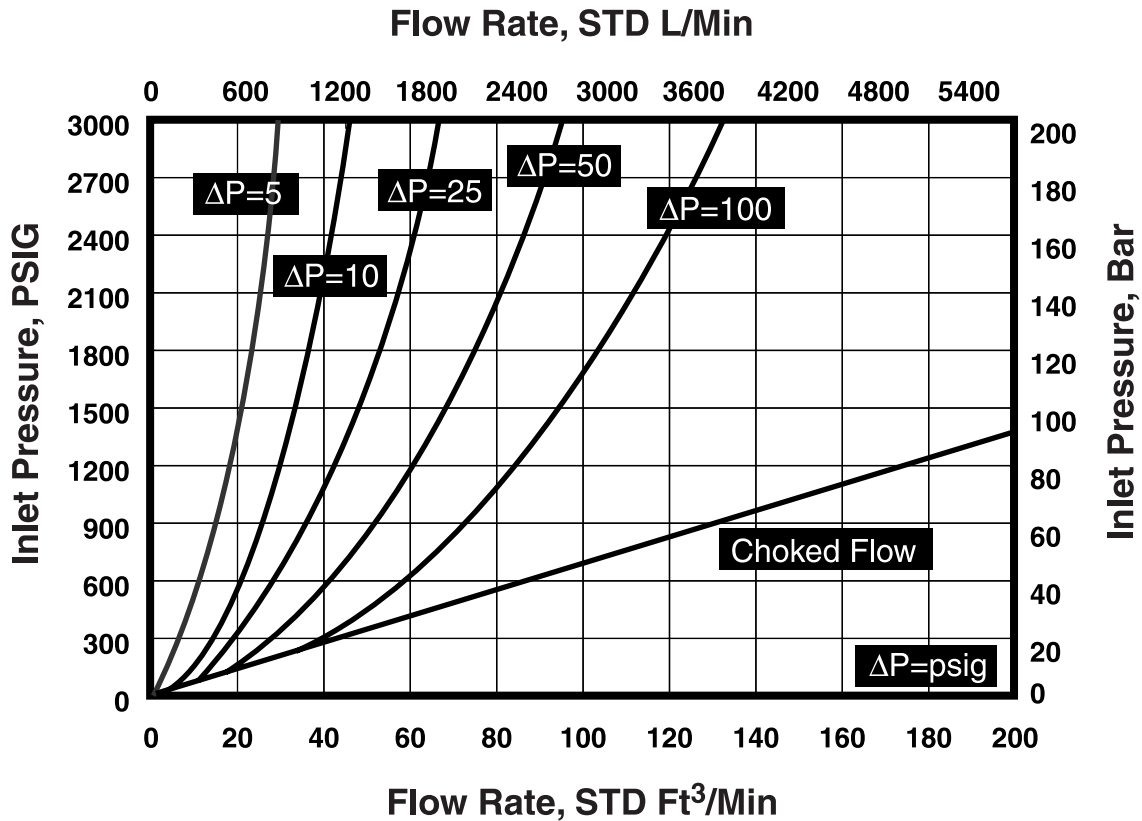

### Ordering Information

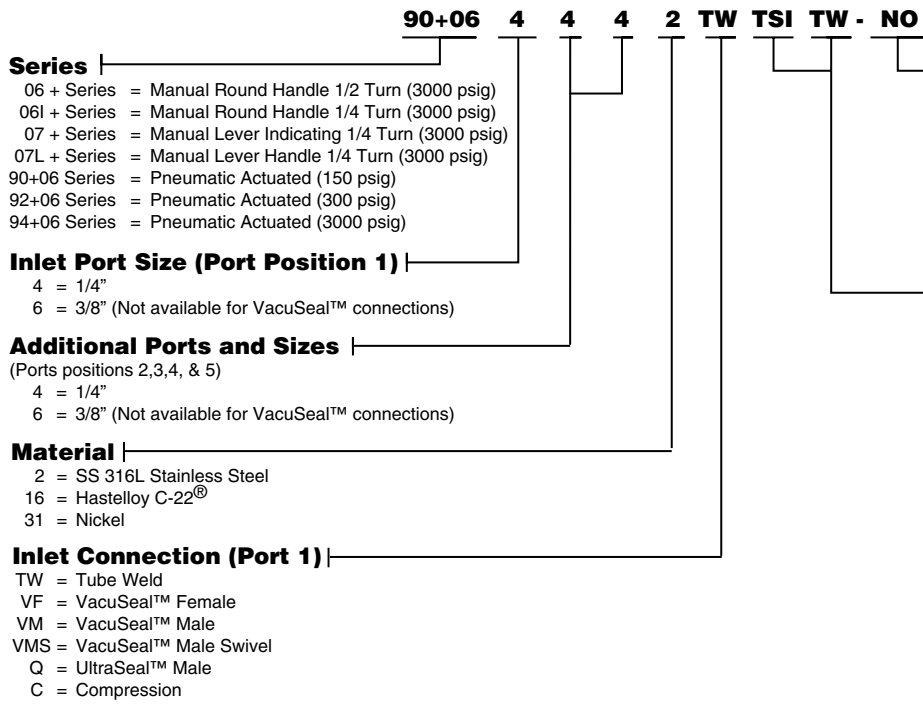

- Optional Features**
- CB1 = Constant Bleed 1 slpm
  - CB3 = Constant Bleed 3 slpm
  - PCTFE Seat (Standard) Leave Blank
  - PI = Vespel® Seat†
  - NO = Normally Open Actuator
  - NC Actuator (Standard) Leave Blank
  - RD = Red Handle
  - BLK = Black Handle
- Additional Ports Connection**
- Ports position 2,3,4 & 5 (Always identify if an inlet, "I")
- TW = Tube Weld
  - TS = Tube Stub (on side ports)
  - VF = VacuSeal™ Female
  - VM = VacuSeal™ Male
  - VMS = VacuSeal™ Male Swivel
  - Q = UltraSeal™ Male
  - C = Compression
  - X = No Port

†Recommended for Nitrous Oxide (N<sub>2</sub>O) Service

VacuSeal™ is a trademark of Parker Hannifin Corporation.  
 UltraSeal™ is a trademark of Parker Hannifin Corporation.  
 Elgiloy® is a registered trademark of Elgiloy Corporation.  
 Hastelloy® is a registered trademark of Haynes International.  
 A-LOK® is a registered trademark of Parker Hannifin Corporation.  
 Vespel® is a registered trademark of DuPont Company.

**Port Position Top View**

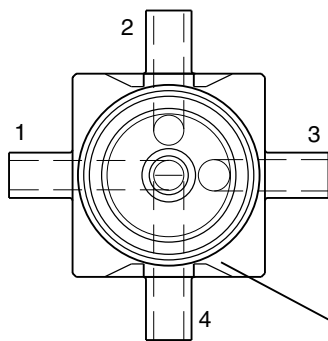

**Front Face**

**Side View**

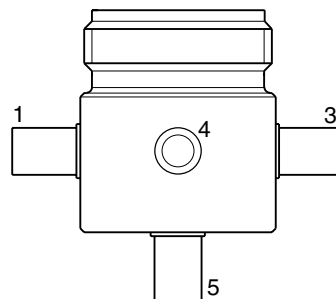



**Parker Hannifin Corporation**

Veriflo Division  
250 Canal Boulevard  
Richmond, CA 94804-0034  
Telephone 510.235.9590  
Fax 510.232.7396  
<http://www.veriflo.com>

Catalog: 4504  
LitPN: 25000178  
Revision: A • 10/03

