



Pressure Regulators

Operating Instructions





WARNING

FAILURE OR IMPROPER SELECTION OR IMPROPER USE OF THIS PRODUCT CAN CAUSE DEATH, PERSONAL INJURY AND PROPERTY DAMAGE.

This document and other information from the Veriflo Division of Parker Hannifin Corporation, its subsidiaries and authorized distributors provides product and/or system options for further investigation by users having technical expertise. It is important that you analyze all aspects of your application, including consequences of any failure and review the information concerning the product or system in the current product catalog. Due to the variety of operating conditions and applications for these products and systems, the user, through its own analysis and testing, is solely responsible for making the final selection of the products and systems and assuring that all performance, safety and warning requirements of the application are met.



WARNING

OXYGEN SERVICE

The user is solely responsible for selecting the regulator and specifying materials to be used in oxygen service. Extreme caution must be taken when using oxygen. A serious risk of ignition, fire, and explosion exists.

- Do not use a regulator or operate a system if there is evidence of contamination (e.g. debris, particles, oils, lubricants, grease, etc.);
- Do not interchange regulators, components, or accessories with those that have been used in other types of gas service;
- Do not operate the regulator without a proper filter;
- Always apply pressure to the regulator slowly to avoid heating from adiabatic compression. Fast opening valves should not be used.



SAFETY PRECAUTIONS

- Users must be trained and equipped for the handling, use and servicing of high-pressure fluids and systems.
- Users must contact their gas or liquid supplier for specific safety precautions and instructions.
- Always wear appropriate protective clothing including approved safety glasses, gloves, aprons, etc.
- Follow all applicable safety and maintenance procedures.
- Obey local, government and agency codes and regulations.
- Do not exceed the maximum inlet and outlet pressures of the product.
- Do not exceed the maximum operating pressure of pressure gauges, connections or other accessories provided with the product. Note that the maximum operating pressure of an accessory may be less than or greater than the maximum inlet pressure marked on the product.
- Operate within the temperature limits and other conditions specified for the product.
- Venting fluids and gases can be dangerous. Vent to a safe environment, away from employees. Ensure adequate ventilation to prevent suffocation.

Questions regarding the installation, operation, and maintenance of a Veriflo product should be directed to (510) 235-9590 in the U.S. or visit our web site at www.veriflo.com.

Veriflo Division

Parker Hannifin Corporation
250 Canal Boulevard, P.O. Box 4034
Richmond, CA 94804-0034
Phone (510) 235-9590
Fax (510) 232-7396

LITP/N: 25000169
Revision: 0 • 2/03

Installation

Veriflo offers a variety of pressure regulators with various inlet connections, outlet connections, and pressure gauges and other options. Before installing the regulator you should fully understand the options of your particular regulator and its suitability for the application.

- Step 1** Verify that the regulator is rated for the system operating pressures and has the proper connections and accessories for the type of gas and pressures required for your application.
- Step 2** Verify the high pressure gauge is suitable for the pressure of the system or cylinder.
- Step 3** Inspect the regulator and your system connections for evidence of contamination or damage. Regulators that are damaged or contaminated should not be used.
- Step 4** The fluid supplied to the regulator must be clean. Contamination can damage the regulator's seat and cause the regulator to malfunction. An upstream filter is recommended. Additionally, the gas supply should be dry. Condensation caused by expansion of the gas through the regulator and high flows may cause the regulator to function improperly.
- Step 5** Connect the port marked "HP" to the high pressure supply side of your system or cylinder valve and the "LP" port to low or regulated pressure side of your system.

Note: Two stage pressure regulators may have a medium pressure port marked "MP".

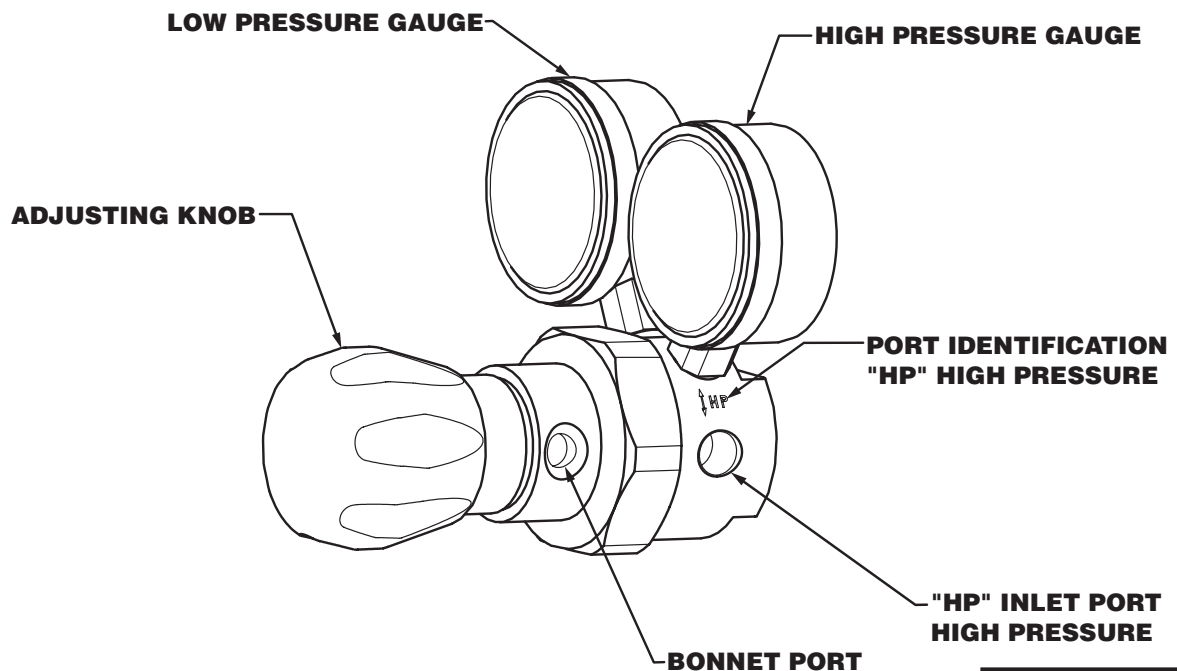

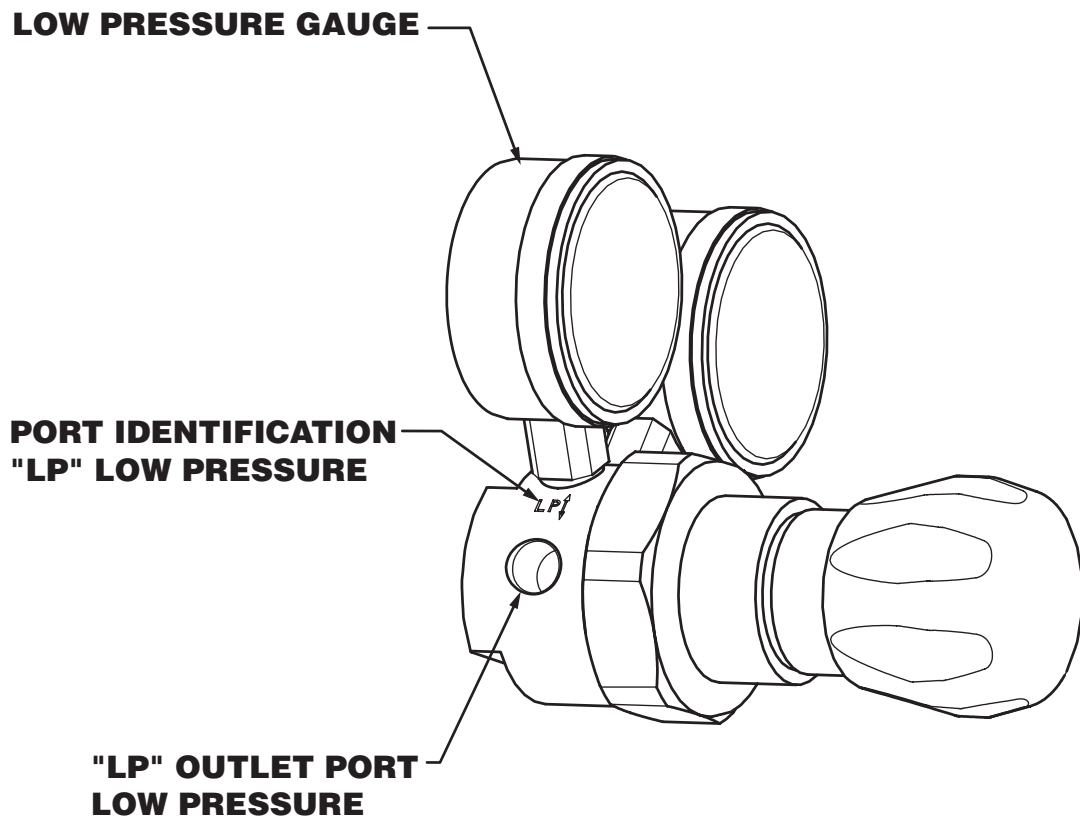

- Step 6** Securely tighten connection fittings in accordance with procedures recommended by the fitting manufacturer or appropriate industry standards.
- Step 7** Perform leak tests to verify there are no leaks to atmosphere or across the regulator seat. Leak test methods should be appropriate for the system leak integrity requirements.
- Step 8** Close the regulator by turning the adjusting knob counterclockwise until the stop is reached. (See special instructions for preset and dome operated regulators.)
- Step 9** Slowly open the supply valve allowing pressure to the regulator to rise gradually. When applying pressure, stand such that the regulator outlet and adjusting knob are not pointing at you. If using a cylinder, stand such that the cylinder valve is between you and the regulator.
- Step 10** When the high pressure gauge indicates the proper supply pressure, open the supply valve or cylinder valve fully.
- Step 11** The regulator is now ready for operation.

Operation



WARNING

Regulator Operation Precautions

- Regulators should not be allowed to flow unrestricted to atmospheric pressure for any extended period of time. Such operation could result in excessive wear and improper regulator operation.
- System flow or downstream system venting is required when the adjusting knob of tied diaphragm regulators are turned counterclockwise to decrease delivery pressure. Not following this precaution may cause regulator damage.
- Pressure relief devices should be used downstream of the regulator to protect equipment from excessive pressure that may result from regulator wear, improper installation or improper operation.
- Exposing the low pressure side of a regulator to high pressure is dangerous and will damage the regulator. Use check valves to prevent back pressure.

Adjusting Pressure: Turning the adjusting knob clockwise will increase the delivery pressure. It is recommended to have flowing gas when adjusting pressure. Turning the adjusting knob counter clockwise will decrease delivery pressure when gas is flowing. If gas is not flowing it will be necessary to vent the downstream system to reduce the pressure. (**See special instructions for self-relieving, preset and dome operated regulators.**) When setting the delivery pressure, the user must ensure that the maximum outlet pressure of the regulator is not exceeded for all operating conditions including increases in delivery pressure due to flow shutoff and supply pressure effect.

Flow Shutoff: The regulator delivery pressure will rise as flow is decreased. After flow is stopped, there will be a small rise in the delivery pressure. The rise in pressure is typically referred to as lockup or creep. A regulator should not be used as a shutoff valve. Close the supply valve or cylinder valve when equipment is not operating or is unattended.

Supply Pressure Effect (SPE): SPE is the increase in delivery pressure that occurs due to falling supply pressure as a gas cylinder is emptied. The approximate increase in delivery pressure can be determined from the SPE coefficient, also referred to as the regulation coefficient. The coefficient represents the delivery pressure increase for every 100 psi decrease in supply pressure. Each regulator model has its own unique SPE coefficient. The rise in outlet pressure due to SPE can cause a significant and dangerous pressure change. The following example demonstrates how to determine the increase in delivery pressure due to SPE.

Example

SPE coefficient: 0.6 psig per 100 psig (see product literature)
Starting cylinder pressure: 2200 psig
Final cylinder pressure: 400 psig

$$\begin{aligned} \text{Delivery Pressure Increase} &= \text{SPE} \times (\text{Starting Cylinder Pressure} - \text{Final Cylinder Pressure}) \\ &= (0.6 \div 100) \times (2200 - 400) = 11 \text{ psi} \end{aligned}$$

Special Instructions

Preset Regulators: Preset regulators do not have an adjusting knob and are set at the factory to provide a specified delivery pressure at a specific supply pressure and flow condition. When pressure is applied to the inlet of the preset regulator, the delivery pressure may exceed the specified delivery pressure if the system is not flowing gas. The downstream system must be flowing or vented to reduce the pressure to the preset delivery pressure.

Dome Operated Regulators: Dome operated regulators do not have an adjusting knob. Regulator delivery pressure is controlled by supplying air or nitrogen gas pressure to a port in the regulator bonnet. Delivery pressure is increased as dome pressure is increased and decreased as dome pressure is decreased. If gas is not flowing it will be necessary to vent the downstream system to reduce the pressure.

When using dome operated regulators adhere to the following precautions:

- Do allow the dome pressure to exceed the maximum outlet pressure of the regulator.
- Ensure that inlet pressure is present at all times when dome pressure is applied. Applying dome pressure without inlet pressure may cause the regulator to malfunction.



Self-Relieving Regulators: Self-relieving regulators vent downstream pressure when the regulator delivery pressure is decreased. Downstream pressure is vented through the regulator's bonnet port as the adjusting knob is turned counter clockwise. When using self-relieving regulators adhere to the following precautions:

- The self-relieving option is not an overpressure protection device. Proper pressure relief devices should be used to provide overpressure protection downstream of the regulator.
- Do not use self-relieving regulators with hazardous gases.

Maintenance



WARNING

IMPROPER REPAIR OR SERVICING OF THIS PRODUCT CAN CAUSE DEATH, PERSONAL INJURY AND PROPERTY DAMAGE.

Veriflo Division products must pass rigid acceptance tests before leaving the factory. All repairs and servicing of this product must only be performed by factory certified personnel and tested for operation and leakage. Veriflo Division cannot assume responsibility for the performance or safety of a customer repaired or serviced product or for any damages resulting from failure of a customer repaired or serviced product or otherwise altered product.

Maintenance: A pressure regulator should be checked periodically for proper and safe operation. A pressure regulator should also be checked after cylinder changes or system maintenance. The user is solely responsible for determining the frequency of maintenance based on the application, that the recommended checks can be safely performed, and that the recommended checks are adequate to ensure proper and safe operation of the user's system. **A regulator that does not comply with the recommended checks or malfunctions in any manner must be immediately removed from service. Do not attempt to repair the regulator.**

- Check for regulator seat leak. Leak test methods should be appropriate for the system leak integrity requirements. Suggested method: Fully close the regulator by turning the adjusting knob counter clockwise until the stop is reached. Apply pressure to the regulator inlet. Close the upstream supply valve. Monitor the pressure between the supply valve and the regulator for 5 minutes. The pressure should not decrease.
- Check flow shutoff. Confirm after flow is stopped, that delivery pressure does not exceed the regulator's maximum outlet pressure.



- Check the regulator function. Confirm delivery pressure increases when the adjusting knob is turned clockwise and decreases when turned counter clockwise. To decrease delivery pressure the system must be flowing or vent the downstream system.
- Check for leaks to atmosphere. There should be no leaks to atmosphere. Leak test methods should be appropriate for the system leak integrity requirements.

Removing a regulator from service: Follow your system safety and maintenance procedures when removing a regulator from service. Before removing the regulator, the user must:

- Isolate the regulator from all pressure sources upstream and downstream of the regulator by closing the appropriate valves.
- Lockout valves and other system equipment needed to isolate pressure sources.
- Properly purge hazardous gases from the regulator.
- Vent all pressure in the regulator. The regulator adjusting knob should be turned clockwise to fully open the regulator to ensure pressure is not trapped in the regulator.

