



Diaphragm Valves

Operating Instructions





WARNING

FAILURE OR IMPROPER SELECTION OR IMPROPER USE OF THIS PRODUCT CAN CAUSE DEATH, PERSONAL INJURY AND PROPERTY DAMAGE.

This document and other information from the Veriflo Division of Parker Hannifin Corporation, its subsidiaries and authorized distributors provides product and/or system options for further investigation by users having technical expertise. It is important that you analyze all aspects of your application, including consequences of any failure and review the information concerning the product or system in the current product catalog. Due to the variety of operating conditions and applications for these products and systems, the user, through its own analysis and testing, is solely responsible for making the final selection of the products and systems and assuring that all performance, safety and warning requirements of the application are met.

The products described herein, including without limitation, product features, specifications, designs, availability and pricing, are subject to change by Veriflo Division, Parker Hannifin Corporation and its subsidiaries at any time without notice.



WARNING

OXYGEN SERVICE

The user is solely responsible for selecting the valve and specifying materials to be used in oxygen service. Extreme caution must be taken when using oxygen. A serious risk of ignition, fire, and explosion exists

- Do not use a valve or operate a system if there is evidence of contamination (e.g. debris, particles, oils, lubricants, grease, etc.);
- Do not interchange valves, components, or accessories with those that have been used in other types of gas service;
- Always open a valve slowly to avoid heating from adiabatic compression. Fast opening valves should not be used.



SAFETY PRECAUTIONS

- Users must be trained and equipped for the handling, use and servicing of high-pressure fluids and systems.
- Users must contact their gas or liquid supplier for specific safety precautions and instructions.
- Always wear appropriate protective clothing including approved safety glasses, gloves, aprons, etc.
- Follow all applicable safety and maintenance procedures.
- Obey local, government and agency codes and regulations.
- Do not exceed the maximum inlet and outlet pressures of the product.
- Do not exceed the maximum operating pressure of pressure gauges, connections or other accessories provided with the product. Note that the maximum operating pressure of an accessory may be less than or greater than the maximum inlet pressure marked on the product.
- Operate within the temperature limits and other conditions specified for the product.
- Venting fluids and gases can be dangerous. Vent to a safe environment, away from employees. Ensure adequate ventilation to prevent suffocation.

Questions regarding the installation, operation, and maintenance of a Veriflo product should be directed to (510) 235-9590 in the U.S. or visit our web site at www.veriflo.com.

Veriflo Division

Parker Hannifin Corporation
250 Canal Boulevard, P.O. Box 4034
Richmond, CA 94804-0034
Phone (510) 235-9590
Fax (510) 232-7396

LITP/N: 25000170
Revision: 0 • 2/03

Installation

Veriflo offers a variety of diaphragm valves with various inlet connections, outlet connections, and actuators and other options. Before installing the valve you should fully understand the options of your particular valve and its suitability for the application.

- Step 1** Verify that the valve is rated for the system operating pressures and has the proper connections and options for the type of gas and pressures required for your application.
- Step 2** Inspect the valve and your system connections for evidence of contamination or damage. Valves that are damaged or contaminated should not be used.
- Step 3** The fluid supplied to the valve must be clean. Contamination can damage the valve's seat and cause a leak.
- Step 4** Inlet and outlet connections may be identified by an arrow marked on the body for 2 port valves or by "IN" and "OUT" marking on multiple port valves.

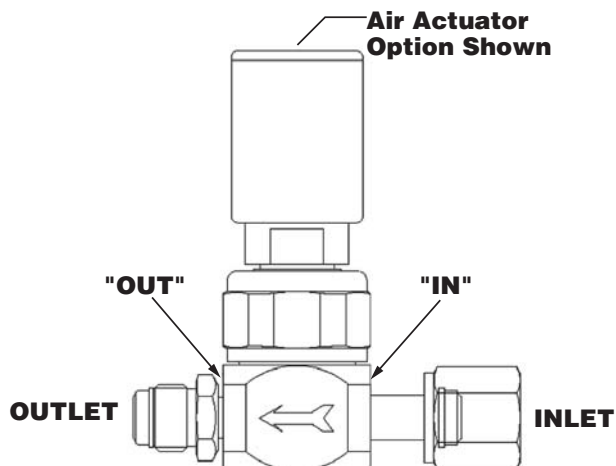

- Step 5** Securely tighten connection fittings in accordance with procedures recommended by the fitting manufacturer or appropriate industry standards.
- Step 6** Perform leak tests to verify there are no leaks to atmosphere or across the valve seat. Leak test methods should be appropriate for the system leak integrity requirements.
- Step 7** Follow all applicable safety and maintenance procedures for your system before applying system pressure.
- Step 8** The valve is now ready for operation.

Operation

Manual Valves

- To open the valve: Turn the handle counterclockwise until the stop is reached.
- To close the valve: Turn the handle clockwise until the valve is fully closed.

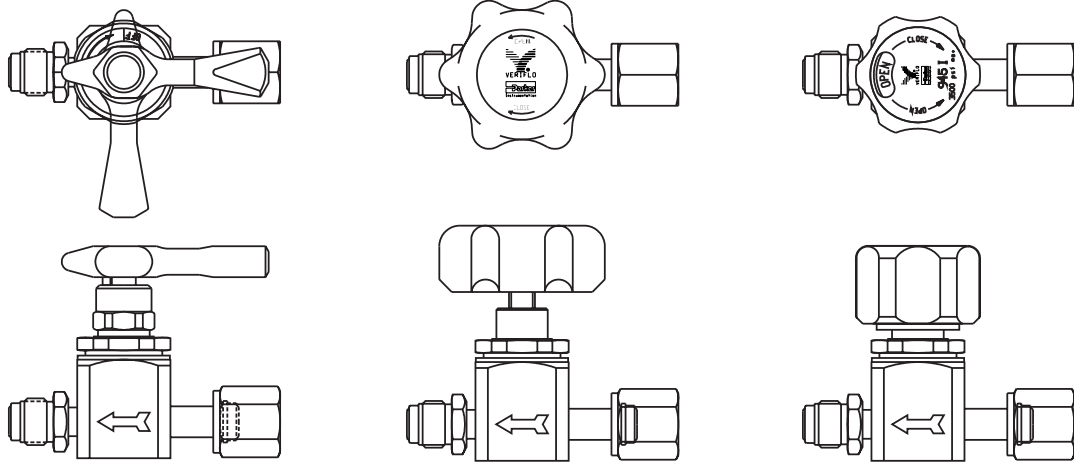

Lever Valve

Hand Wheel Valve

Indicator Valve

Toggle Valves

- To open the valve: Place the lever in the vertical position.
- To close the valve: Place the lever in the horizontal position.

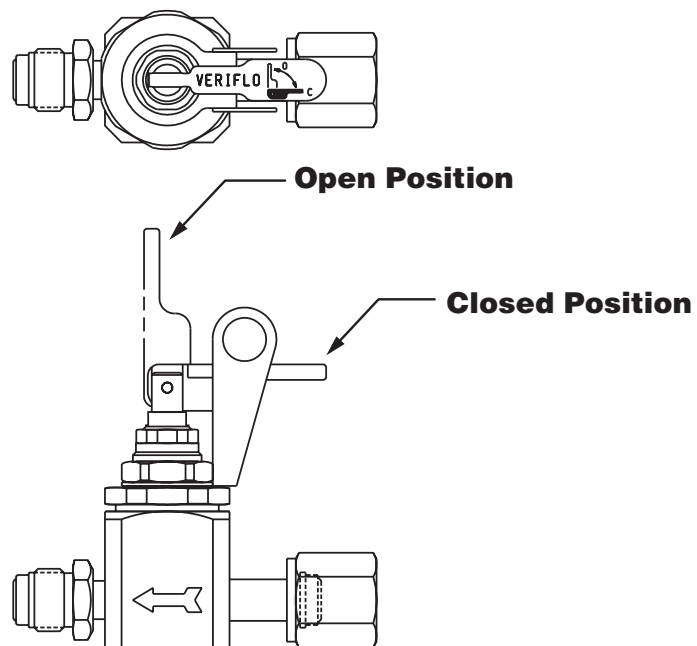

Air Operated Valves, Normally Closed

- To open the valve: Apply 70 -100 psig to the actuator port.
- To close the valve: Vent the pressure to the actuator to 0 psig.

Air Operated Valves, Normally Open

- To open the valve: Vent the pressure to the actuator to 0 psig.
- To close the valve: Apply 70 -100 psig to the actuator port.

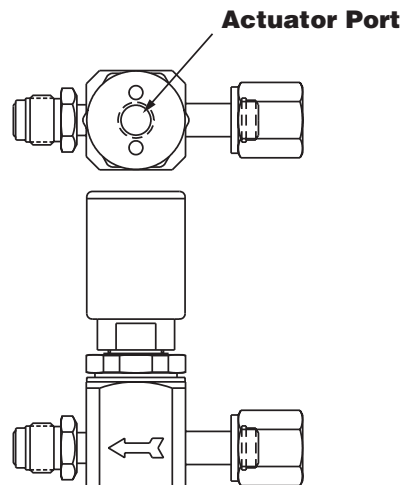

Maintenance



WARNING

IMPROPER REPAIR OR SERVICING OF THIS PRODUCT CAN CAUSE DEATH, PERSONAL INJURY AND PROPERTY DAMAGE.

Veriflo Division products must pass rigid acceptance tests before leaving the factory. All repairs and servicing of this product must only be performed by factory certified personnel and tested for operation and leakage. Veriflo Division cannot assume responsibility for the performance or safety of a customer repaired or serviced product or for any damages resulting from failure of a customer repaired or serviced product or otherwise altered product.

Veriflo valves are packless and do not require packing adjustment. Do not loosen or remove the clamp nut. A valve should be checked periodically for proper and safe operation. A valve should also be checked after cylinder changes or system maintenance. The user is solely responsible for determining the frequency of maintenance based on the application, that the recommended checks can be safely performed, and that the recommended checks are adequate to ensure proper and safe operation of the user's system. A valve that does not comply with the recommended checks or malfunctions in any manner must be immediately removed from service. Do not attempt to repair the valve.

- Check for valve seat leak. With the valve closed, there should be no leak across the valve seat. Leak test methods should be appropriate for the system leak integrity requirements.
- Check for leaks to atmosphere. With the valve open, there should be no leaks to atmosphere. Leak test methods should be appropriate for the system leak integrity requirements.

Removing a valve from service: Follow your system safety and maintenance procedures when removing a valve from service. Before removing a valve, the user must:

- Isolate the valve from all pressure sources upstream and downstream of the valve by closing the appropriate valves.
- Lockout valves and other system equipment needed to isolate pressure sources.
- Properly purge hazardous gases from the valve.
- Vent all pressure in the valve. The valve should be open to ensure pressure is not trapped in the valve.

