



**Performance Stainless**  
**Sanitary Fittings & Flow Components**

*Catalog 4270 - Sanitary Fittings*  
*January 2005*



## If your processing system demands high performance flow components...

*Your system deserves Parker Performance Stainless.*



As a global leader in the motion and control industry, Parker Hannifin understands the pressures of running a modern production facility. Each function is critical, and breakdowns cost money. The last thing you need to be concerned about are products or equipment that do not perform as expected. Parker is committed to

supplying sanitary fluid processors with world class flow components, at a price that is affordable. Our only commitment is to your satisfaction.

### A part is only as good as the whole!

At Parker, we believe our components are only a part of the team it takes to service our customers. We rely on a highly-technical and dedicated worldwide group of distributors and agents referred to as the Performance Team. They deliver the extra value that sets us apart from the pack. Our people lead the race in quality service.

As a customer, we want you to be a lifelong member of the Performance Team, and we welcome your continued feedback about our performance. We want this to be the best flow components company in the world, and your role in our success is important. If you are in need of a special part or component, or some other service, please contact us or one of our Performance Team members.



© Copyright 2003, Parker Hannifin Corporation. All Rights Reserved.

## INDEX

Introduction .....Page 2  
Ordering Information .....Page 3

### WELD FITTINGS

Elbows .....Page 4  
Tees & Crosses .....Page 5  
Reducers .....Page 6

### CLAMP FITTINGS

Elbows & Reducers .....Page 6-7  
Tees & Crosses .....Page 8  
Ferrules .....Page 9-10  
NPT Adapters .....Page 11  
Adapters .....Page 12  
Hangers & Clamps.....Page 13-14

### BEVEL SEAT FITTINGS & FULL LINE GASKETS

Clamps .....Page 14  
End Cap, Hex Nut & Wrench.....Page 15  
Gaskets.....Page 16

### FLOW COMPONENTS & ADAPTERS

Miscellaneous Flow  
Components & Adapters .....Page 17-18

### GENERAL INFORMATION

BPE Compliant Fittings .....Page 19  
Product Family.....Page 20  
Reference Charts.....Page 21  
Offer Of Sale .....Page 22  
Parker Performance Stainless .....Page 23

### Offer of Sale

The items described in this document are hereby offered for sale by Parker Hannifin Corporation, its subsidiaries or its authorized distributors. This offer and its acceptance are governed by the provisions stated in the Parker Performance Stainless Catalog 4270.

### ⚠ WARNING

FAILURE, IMPROPER SELECTION OR IMPROPER USE OF THE PRODUCTS AND/OR SYSTEMS DESCRIBED HEREIN OR RELATED ITEMS CAN CAUSE DEATH, PERSONAL INJURY AND PROPERTY DAMAGE.

This document and other information from Parker Hannifin Corporation, its subsidiaries and authorized distributors provide product and/or system options for further investigation by users having technical expertise. It is important that you analyze all aspects of your application and review the information concerning the product or system in the current product catalog. Due to the variety of operating conditions and applications for these products or systems, the user, through its own analysis and testing, is solely responsible for making the final selection of the products and systems and assuring that all performance, safety and warning requirements of the application are met.

The products described herein, including without limitation, product features, specifications, designs, availability and pricing, are subject to change by Parker Hannifin Corporation and its subsidiaries at any time without notice.

To specify the part completely, start with the description and select each of the additional options shown below. Be sure to denote the material and polish combination. See the example below.

## PART NUMBER EXAMPLE

①      ②      ③      ④  
**2CMP - 2.0 - 316 - 7**

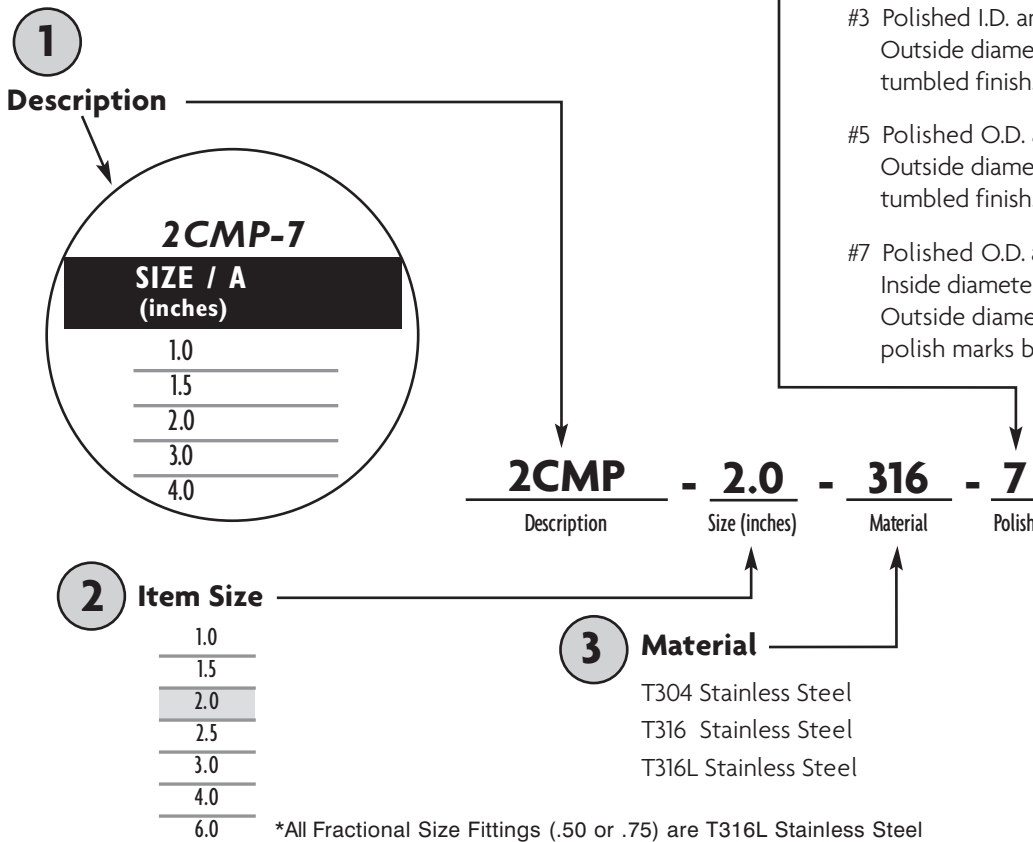

**BPE SIZE ONLY** (Item Meets ASME - BPE Size Only Specifications)

- Notes about the Dimension Tables**
- All Dimension are in inches.
  - Wall Thickness:
    - Fittings in 1.0-3.0 sizes are manufactured with 16 gauge (.065) wall thickness.
    - Fittings in 4.0 tube size are manufactured with 14 gauge (.083) wall thickness.

### QUALITY STATEMENT:

All fittings shall be manufactured using high quality T-304 or T-316L Stainless Steel with an A-269 minimum wall tubing. Fittings shall be free of crevices and manufactured within close, industry accepted tolerances. Standard polish shall be 180 grit ID and 150 grit OD, with capabilities up to 320 grit. Fittings shall meet 3A standards where applicable. Full heat traceability shall be made available on all 316L material. Fittings .50 through 3.0 shall have a uniform .065 gauge, size 4.0 shall be .083 and size 6.0 shall be .109.



L2S

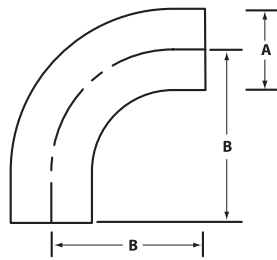

2WCL

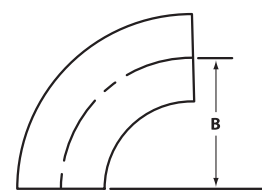

## L2S - 90° Tube Bend “Long”

SIZE A (inches)	B (inches)	NOMINAL WALL THICKNESS
1.0	2.062	.065
1.5	2.937	.065
2.0	4.062	.065
2.5	5.187	.065
3.0	6.312	.065
4.0	8.312	.083
6.0	9.000	.109

## 2WCL - 90° Tube Bend “Short”

B (inches)	NOMINAL WALL THICKNESS
1.50	.065
2.25	.065
3.00	.065
3.75	.065
4.50	.065
6.00	.083
9.00	.109



L2KS

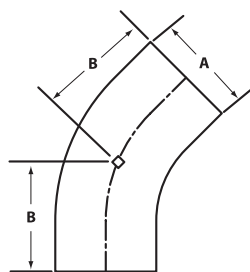

2WK

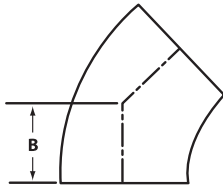

## L2KS - 45° Tube Bend “Long”

SIZE A (inches)	B (inches)	NOMINAL WALL THICKNESS
1.0	1.187	.065
1.5	1.625	.065
2.0	2.312	.065
2.5	3.000	.065
3.0	3.687	.065
4.0	4.812	.083
6.0	3.750	.109

## 2WK - 45° Tube Bend “Short”

B (inches)	NOMINAL WALL THICKNESS
.625	.065
.938	.065
1.250	.065
1.563	.065
1.875	.065
2.500	.083
3.750	.109



L2CM

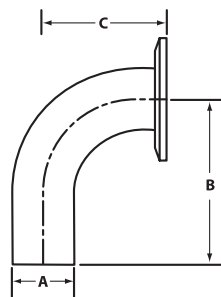

## L2CM - 90° Clamp One End

SIZE A (inches)	B (inches)	C (inches)	NOMINAL WALL THICKNESS
1.0	2.062	2.562	.065
1.5	2.937	3.437	.065
2.0	4.062	4.562	.065
2.5	5.187	5.687	.065
3.0	6.312	6.812	.065
4.0	8.312	8.937	.083
6.0	9.000	9.750	.109



L2KM

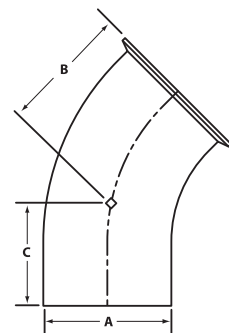

## L2KM - 45° Clamp One End

SIZE A (inches)	B (inches)	C (inches)	NOMINAL WALL THICKNESS
1.0	1.687	1.187	.065
1.5	2.125	1.625	.065
2.0	3.812	2.312	.065
2.5	3.500	3.000	.065
3.0	4.187	3.687	.065
4.0	5.437	4.812	.083
6.0	4.500	3.750	.109

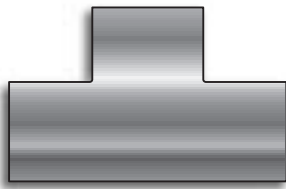

**L7WWW**

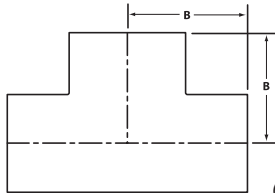
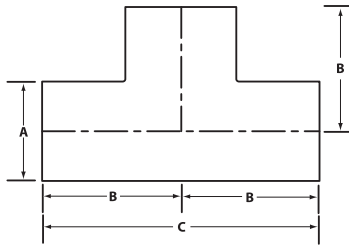

**7W "SHORT"**

(TUMBLE FINISH ONLY)

**L7WWW - Tee**

SIZE A (inches)	B (inches)	C (inches)	NOMINAL WALL THICKNESS
1.0	1.875	3.75	.065
1.5	2.250	4.50	.065
2.0	3.000	6.00	.065
2.5	3.000	6.00	.065
3.0	3.250	6.50	.065
4.0	3.875	7.75	.083
6.0	5.625	11.25	.109

**7W - Tee "Short"**

SIZE (inches)	B (inches)	NOM. WALL THICKNESS
1.0	1.125	.065
1.5	1.656	.065
2.0	2.062	.065
2.5	2.344	.065
3.0	2.594	.065
4.0	3.438	.083

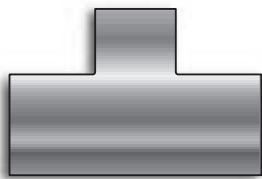

**L7RW**

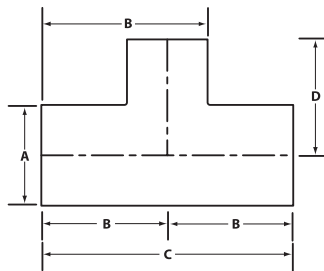

**L7RW - Reducing Tee (Reduction on Branch)**

SIZE A (inches)	B (inches)	C (inches)	D (inches)	NOMINAL WALL THICKNESS
1.5 x 1.0	1.5	3.00	3.312	.065
2.0 x 1.0	2.0	4.00	4.125	.065
2.0 x 1.5	2.0	4.00	4.125	.065
2.5 x 1.0	2.5	5.00	4.687	.065
2.5 x 1.5	2.5	5.00	4.687	.065
2.5 x 2.0	2.5	5.00	4.687	.065
3.0 x 1.0	3.0	6.00	5.187	.065
3.0 x 1.5	3.0	6.00	5.187	.065
3.0 x 2.0	3.0	6.00	5.187	.065
3.0 x 2.5	3.0	6.00	5.187	.065
4.0 x 1.0	4.0	8.00	9.250	.083
4.0 x 1.5	4.0	8.00	9.250	.083
4.0 x 2.0	4.0	8.00	9.250	.083

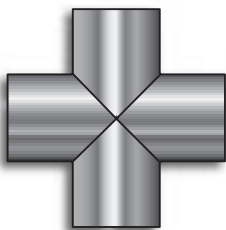

**L9W**

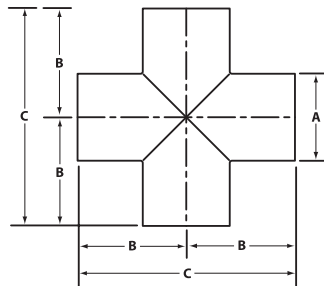

**L9W - Cross**

SIZE A (inches)	B (inches)	C (inches)	NOMINAL WALL THICKNESS
1.0	1.125	2.250	.065
1.5	1.656	3.312	.065
2.0	2.062	4.125	.065
2.5	2.343	4.687	.065
3.0	2.593	5.187	.065
4.0	3.437	6.875	.083
6.0	5.000	10.00	.109

## Butt Weld Fittings: REDUCERS

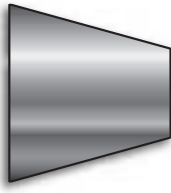

L31

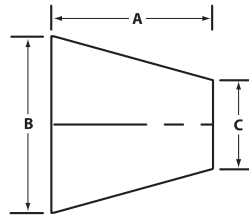

### L31 - Concentric Reducers

SIZE A (inches)	B (inches)	C (inches)	NOMINAL WALL THICKNESS
1.5 x 1.0	2.000	1.500	.065
2.0 x 1.0	2.000	2.000	.065
2.0 x 1.5	2.000	2.000	.065
2.5 x 1.5	4.000	2.500	.065
2.5 x 2.0	2.000	2.500	.065
3.0 x 1.5	6.000	3.000	.065
3.0 x 2.0	4.000	3.000	.065
3.0 x 2.5	2.000	3.000	.065
4.0 x 1.5	10.00	4.000	.083
4.0 x 2.0	8.000	4.000	.083
4.0 x 2.5	6.000	4.000	.083
4.0 x 3.0	4.000	4.000	.083
6.0 x 4.0	9.000	6.000	.109

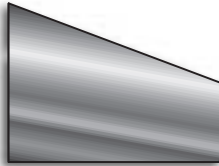

L32

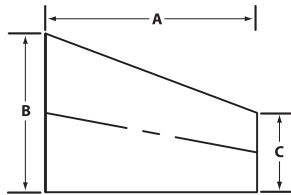

### L32 - Eccentric Reducers

SIZE A (inches)	B (inches)	C (inches)	NOMINAL WALL THICKNESS
1.5 x 1.0	2.000	1.500	.065
2.0 x 1.0	4.000	2.000	.065
2.0 x 1.5	2.000	2.000	.065
2.5 x 1.5	4.000	2.500	.065
2.5 x 2.0	2.000	2.500	.065
3.0 x 1.5	6.000	3.000	.065
3.0 x 2.0	4.000	3.000	.065
3.0 x 2.5	2.000	3.000	.065
4.0 x 1.5	10.00	4.000	.083
4.0 x 2.0	8.000	4.000	.083
4.0 x 2.5	6.000	4.000	.083
4.0 x 3.0	4.000	4.000	.083
6.0 x 4.0	5.500	6.000	.109

## Clamp Fittings: ELBOWS



2CMP

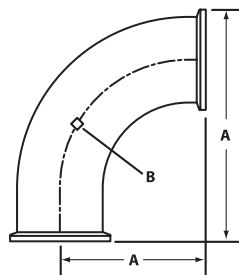

### 2CMP - 90° EII BPE SIZE ONLY

SIZE (inches)	A (inches)	B (inches)
1.0	2.000	1.500
1.5	2.750	2.250
2.0	3.500	3.000
2.5	4.250	3.750
3.0	5.000	4.500
4.0	6.625	6.000
6.0	9.750	9.000

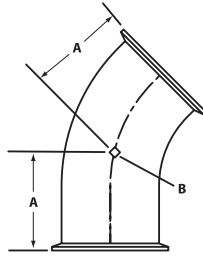

**2KMP - 45° ELL** BPE SIZE ONLY

SIZE (inches)	A (inches)	B (inches)
1.0	1.125	1.500
1.5	1.437	2.250
2.0	1.750	3.000
2.5	2.062	3.750
3.0	2.375	4.500
4.0	3.125	6.000
6.0	4.500	9.000

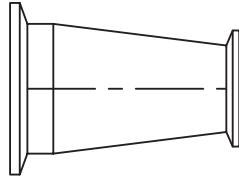
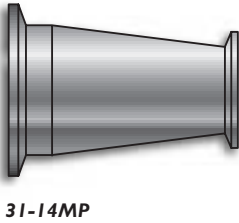

**31-14MP - Concentric Reducer** BPE SIZE ONLY

SIZE (inches)	OVERALL LENGTH
1.5 x 1.0	3.000
2.0 x 1.0	5.000
2.0 x 1.5	3.000
2.5 x 1.5	5.000
2.5 x 2.0	3.000
3.0 x 1.5	7.000
3.0 x 2.0	5.000
3.0 x 2.5	3.000
4.0 x 1.5	11.125
4.0 x 2.0	9.125
4.0 x 2.5	7.125
4.0 x 3.0	5.125
6.0 x 4.0	10.500

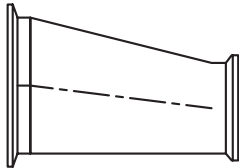
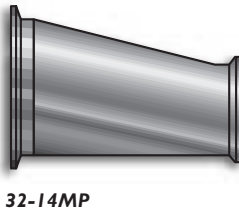

**32-14MP - Eccentric Reducers** BPE SIZE ONLY

SIZE (inches)	OVERALL LENGTH
1.5 x 1.0	3.000
2.0 x 1.0	5.000
2.0 x 1.5	3.000
2.5 x 1.5	5.000
2.5 x 2.0	3.000
3.0 x 1.5	7.000
3.0 x 2.0	5.000
3.0 x 2.5	3.000
4.0 x 1.5	11.125
4.0 x 2.0	9.125
4.0 x 2.5	7.125
4.0 x 3.0	5.125
6.0 x 4.0	10.500



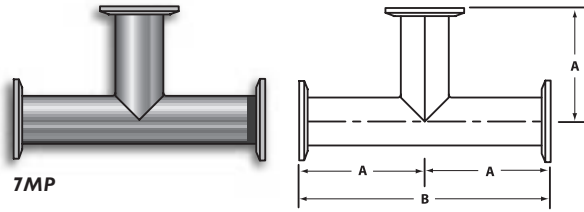

7MP

## 7MP - Tee

SIZE (inches)	A (inches)	B (inches)
1.0	2.375	4.750
1.5	2.750	5.500
2.0	3.500	7.000
2.5	3.500	7.000
3.0	3.750	7.500
4.0	4.500	9.000
6.0	7.150	14.300

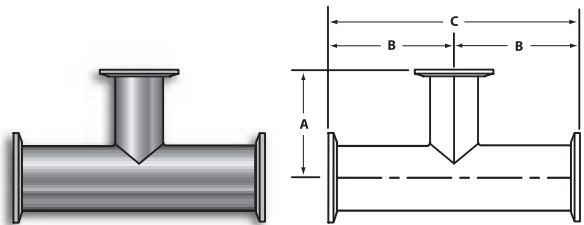

7RMP - Size Reduced on Branch

## 7RMP - Reducing Tee

SIZE (inches)	A (inches)	B (inches)	C (inches)
1.5 x 1.0	1.875	2.156	4.312
2.0 x 1.0	2.125	2.562	5.125
2.0 x 1.5	2.406	2.562	5.125
2.5 x 1.0	2.812	2.843	5.687
2.5 x 1.5	2.656	2.844	5.688
2.5 x 2.0	2.812	2.843	5.687
3.0 x 1.0	3.062	3.093	6.187
3.0 x 1.5	3.062	3.093	6.187
3.0 x 2.0	3.062	3.093	6.187
3.0 x 2.5	3.093	3.093	6.187
4.0 x 1.0	4.875	4.062	8.125
4.0 x 1.5	4.875	4.062	8.125
4.0 x 2.0	4.875	4.062	8.125
4.0 x 2.5	4.875	4.062	8.125
4.0 x 3.0	4.875	4.062	8.125
6.0 x 2.0	5.500	5.750	11.500
6.0 x 2.5	5.500	5.750	11.500
6.0 x 3.0	5.500	5.750	11.500
6.0 x 4.0	5.625	5.750	11.500

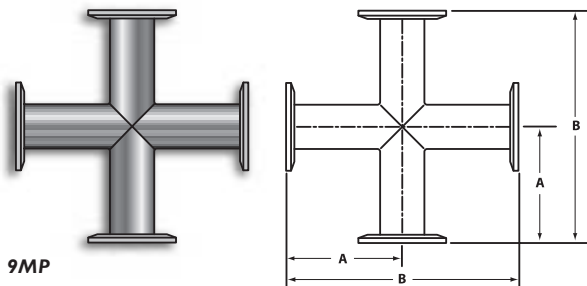

9MP

## 9MP - Cross

SIZE (inches)	A (inches)	B (inches)
1.0	2.375	4.750
1.5	2.750	5.500
2.0	3.500	7.000
2.5	3.500	7.000
3.0	3.750	7.500
4.0	4.500	9.000
6.0	5.750	11.500



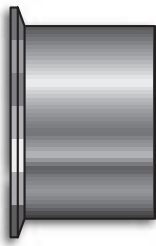

LI4AM

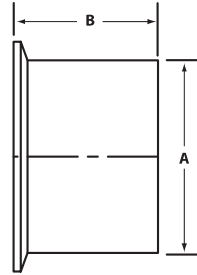

## LI4AM - Butt Welding Ferrule

SIZE A (inches)	B (inches)	NOMINAL WALL THICKNESS
1.0	1.125	.065
1.5	1.125	.065
2.0	1.125	.065
2.5	1.125	.065
3.0	1.125	.065
4.0	1.125	.083
6.0	1.500	.109

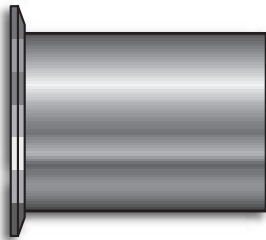

TLI4AM

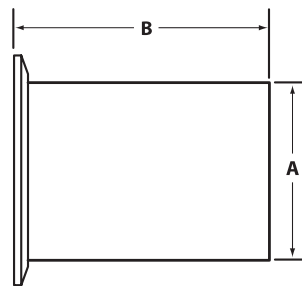

## TLI4AM - Butt Welding Ferrule BPE SIZE ONLY

SIZE A (inches)	B (inches)	NOMINAL WALL THICKNESS
0.50	1.750	.065
0.75	1.750	.065
1.00	1.750	.065
1.50	1.750	.065
2.00	2.250	.065
2.50	2.250	.065
3.00	2.250	.065
4.00	2.250	.083

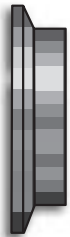

I4WMP



## I4WMP - Short Welding Ferrule

SIZE A (inches)	B (inches)	NOMINAL WALL THICKNESS
1.0	0.500	.065
1.5	0.500	.065
2.0	0.500	.065
2.5	0.500	.065
3.0	0.500	.065
4.0	0.625	.083
6.0	0.750	.109



I6AMP

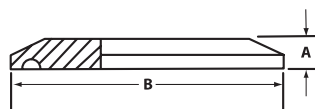

## I6AMP - Solid End Cap

SIZE (TUBE O.D.) (inches)	A (inches)	B (inches)
0.50 / .75	0.250	0.993
1.0 / 1.5	0.250	1.984
2.0	0.250	2.516
2.5	0.250	3.047
3.0	0.250	3.579
4.0	0.312	4.682
6.0	0.500	6.570

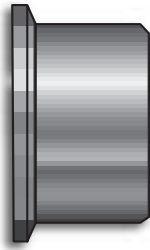

I4RMP

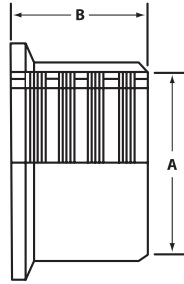

## I4RMP - Recessless Ferrule

SIZE A (inches)	B (inches)
1.0	0.750
1.5	1.125
2.0	1.312
2.5	1.375
3.0	1.437
4.0	1.500

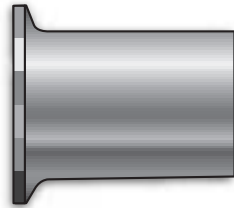

I4WLMP

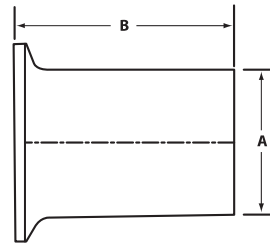

## I4WLMP - Tank Welding Spud-Light

SIZE A (inches)	B (inches)	NOMINAL WALL THICKNESS
1.0	3.000	.065
1.5	3.000	.065
2.0	3.000	.065
2.5	3.000	.065
3.0	4.000	.065
4.0	4.000	.083
6.0	6.000	.109
8.0	6.000	.109
10.0	6.000	.140
12.0	6.000	.140



I4MPW

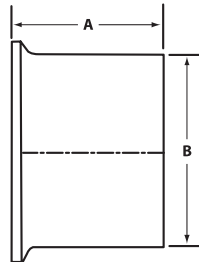

## I4MPW - Tank Welding Ferrule

SIZE (inches)	A (inches)	B (inches)	NOMINAL WALL THICKNESS
0.50	2.125	0.500	.065
0.75	2.125	0.750	.065
1.00	1.625	1.160	.145
1.50	1.625	1.676	.153
2.00	1.750	2.192	.161
2.50	1.750	2.708	.169
3.00	1.812	3.224	.177
4.00	2.125	4.256	.211
6.00	2.125	6.000	.217
8.00	2.125	8.000	.217

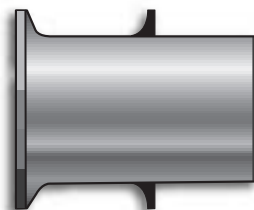

FLVI4AM

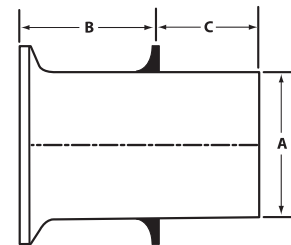

## FLVI4AM - Flowverter Ferrule

SIZE A (inches)	B (inches)	C (inches)	NOMINAL WALL THICKNESS
0.50	1.125	1.000	.065
0.75	1.125	1.000	.065
1.00	1.625	1.000	.065
1.50	1.625	1.000	.065
2.00	1.625	1.000	.065
2.50	1.625	1.000	.065
3.00	1.625	1.000	.065
4.00	1.625	1.000	.083

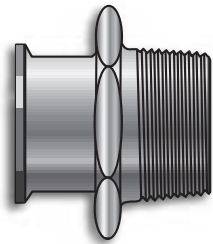

2IMP

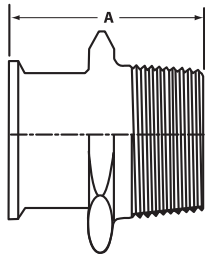

**BPE** SIZE ONLY

\* = No Hex Head Reduction on NPT

## 2IMP - Adapter

(N.P.T. Male Threads)

SIZE (T/C x NPT) (inches)	A (inches)
0.50 x 0.125*	2.000
0.50 x 0.250*	2.000
0.50 x 0.375*	2.000
0.50 x 0.500*	2.000
0.50 x 0.750*	2.000
0.75 x 0.125*	2.000
0.75 x 0.250*	2.000
0.75 x 0.375*	2.000
0.75 x 0.500*	2.000
0.75 x 0.750*	2.000
0.75 x 1.000*	2.250
1.00 x 0.125*	2.187
1.00 x 0.250*	2.161
1.00 x 0.375*	2.187
1.00 x 0.500*	2.187
1.00 x 0.750*	2.187
1.00 x 1.000	2.250
1.00 x 1.500	2.437
1.00 x 2.000	2.625
1.00 x 3.000*	2.625
1.50 x 0.750*	2.187
1.50 x 1.000	2.312
1.50 x 1.250	2.437
1.50 x 1.500	2.437
1.50 x 2.000	2.625
1.50 x 2.500*	3.281
2.00 x 1.000	2.468
2.00 x 1.500	2.468
2.00 x 2.000	2.656
2.00 x 2.500*	3.125
2.00 x 3.000*	3.500
2.00 x 4.000*	3.500
2.50 x 1.000*	2.781
2.50 x 1.500*	2.781
2.50 x 2.000*	2.781
2.50 x 2.500*	3.281
2.50 x 3.000*	3.690
3.00 x 1.000*	3.000
3.00 x 1.500*	3.000
3.00 x 2.000*	3.000
3.00 x 2.500*	3.500
3.00 x 3.000*	3.500
3.00 x 4.000*	3.500
4.00 x 1.500*	3.812
4.00 x 2.000*	3.812
4.00 x 2.500*	3.812
4.00 x 3.000*	3.812
4.00 x 4.000*	3.812
6.00 x 6.000*	4.500

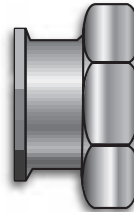

22MP

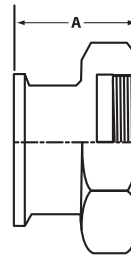

**BPE** SIZE ONLY

\* = No Hex Head Reduction on NPT

## 22MP - Adapter

(N.P.T. Female Threads)

SIZE (T/C x NPT) (inches)	A (inches)
0.50 x 0.125*	1.250
0.50 x 0.250*	1.500
0.50 x 0.375*	1.500
0.50 x 0.500*	1.500
0.50 x 0.750*	1.625
0.50 x 1.000*	1.625
0.50 x 1.500*	2.250
0.50 x 2.000*	2.250
0.75 x 0.125*	1.250
0.75 x 0.250*	1.500
0.75 x 0.375*	1.500
0.75 x 0.500*	1.500
0.75 x 0.750*	1.625
0.75 x 1.000*	1.625
1.00 x 0.750*	1.625
1.00 x 1.000	1.625
1.00 x 1.500	2.250
1.00 x 2.000	2.250
1.00 x 2.500*	2.500
1.50 x 0.750*	1.625
1.50 x 1.000	1.625
1.50 x 1.250	2.250
1.50 x 1.500	2.250
1.50 x 2.000	2.250
1.50 x 2.500*	2.500
1.50 x 3.000*	2.500
2.00 x 1.000	2.500
2.00 x 1.250	1.687
2.00 x 1.500	1.687
2.00 x 2.000	2.343
2.00 x 2.500*	2.406
2.00 x 3.000*	2.406
2.00 x 4.000*	3.000
2.50 x 1.000*	1.312
2.50 x 1.500*	1.656
2.50 x 2.000*	1.718
2.50 x 2.500*	2.093
2.50 x 3.000*	2.187
3.00 x 1.000*	2.187
3.00 x 1.500*	2.187
3.00 x 2.000*	2.187
3.00 x 2.500*	2.187
3.00 x 3.000*	2.187
4.00 x 1.500*	2.187
4.00 x 2.000*	2.187
4.00 x 2.500*	2.187
4.00 x 3.000*	2.187
4.00 x 4.000*	2.625
4.00 x 6.000*	3.250

# Adapters

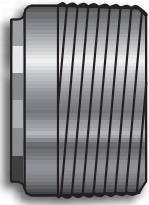

**I9WB**

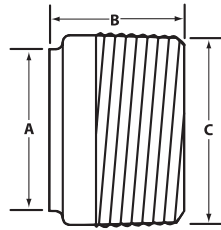

## I9WB - Weld x Male NPT

SIZE A (inches)	B (inches)	C (inches)	NOMINAL TUBE SIZE
0.50	1.500	.8400	.650
0.75	1.625	1.050	.650
1.00	1.750	1.315	.650
1.50	1.750	1.660	.650
2.00	1.812	1.900	.650
2.50	2.312	2.375	.650
3.00	2.500	3.500	.650
4.00	2.562	4.500	.083
6.00	4.000	6.625	.109

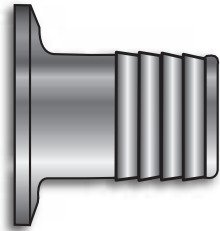

**I4MPHR**

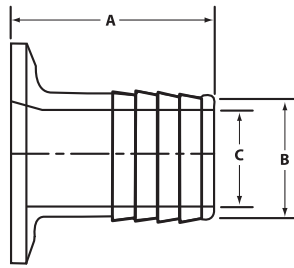

## I4MPHR - Rubber Hose Adapter

SIZE (inches)	A (inches)	B (inches)	C (inches)
1.0 x 1.0	1.687	1.000	0.812
1.5 x 1.5	1.687	1.500	1.312
1.5 x 1.0	1.687	1.000	0.875
2.0 x 2.0	2.312	2.000	1.810
2.0 x 1.5	2.312	1.500	1.312
2.5 x 2.5	2.343	2.500	2.312
3.0 x 3.0	3.093	3.000	2.834
4.0 x 4.0	3.406	4.000	3.834
6.0 x 6.0	3.406	6.000	5.728
8.0 x 8.0	3.406	8.000	7.728



**23BMP**

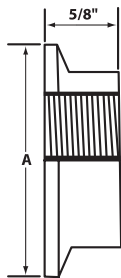

## 23BMP - Thermometer Cap

SIZE (inches)	A (inches)
1.0	1.984
1.5	1.984
2.0	2.516
2.5	3.047
3.0	3.579
4.0	4.682

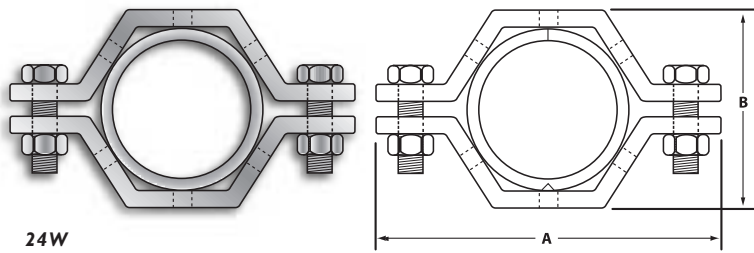

24W

## 24W - Hanger

SIZE (TUBE O.D.) (inches)	A (inches)	B (inches)
1.00	3.375	1.625
1.50	4.000	2.125
2.00	4.500	2.500
2.50	4.750	3.125
3.00	5.000	3.750
4.00	6.750	4.750

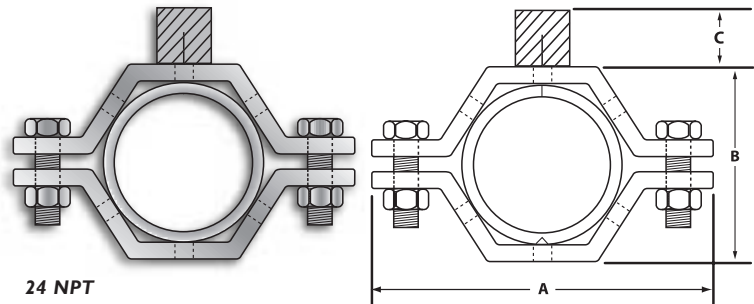

24 NPT

## 24NPT - Hanger (Includes 3/8" NPT Coupler)

SIZE (TUBE O.D.) (inches)	A (inches)	B (inches)	C (inches)
1.00	3.375	1.625	.75
1.50	4.000	2.125	.75
2.00	4.500	2.500	.75
2.50	4.750	3.125	.75
3.00	5.000	3.750	.75
4.00	6.750	4.750	.75

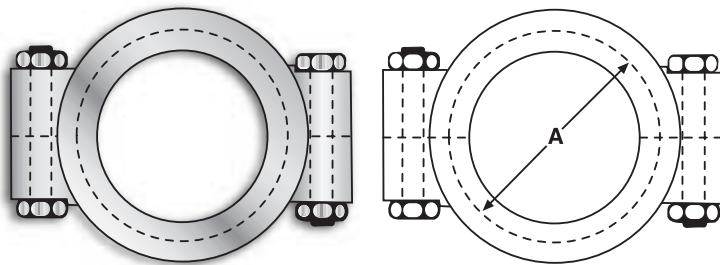

13MHP

## 13MHP - High Pressure Bolted Clamp

SIZE (TUBE O.D.) (inches)	A (inches)
0.50 / 0.75	1.141
1.0 / 1.5	2.046
2.0	2.578
2.5	3.110
3.0	3.640
4.0	4.744
6.0	6.632
8.0	8.632

Size Range: .50 to 8.00 Tube O.D.

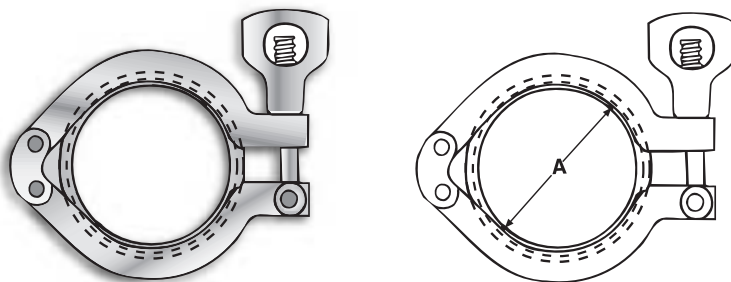

13MHHM

## 13MHHM - Heavy Duty Clamp Double Pin Hinge

SIZE (TUBE O.D.) (inches)	A (inches)
1.0/1.5	2.140
2.0	2.610
2.5	3.141
3.0	3.673
4.0	4.776
6.0	6.695
8.0	8.695
10.0	10.695
12.0	12.695

Size Range: 1.00 to 12.00 Tube O.D.

## Clamp Fittings: CLAMPS

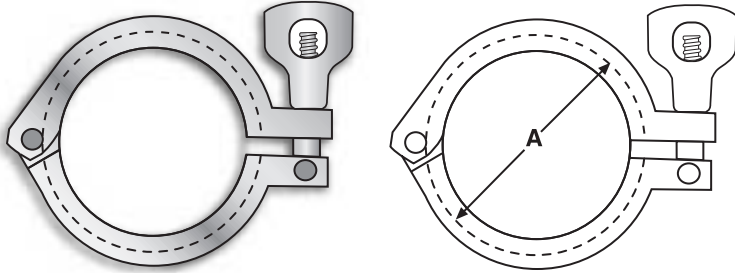

13MHM

### 13MHM - Heavy Duty Clamp Single Pin Hinge

Size Range: .50 to 10.00 Tube O.D.

SIZE (TUBE O.D.) (inches)	A (inches)
0.50 / 0.75	1.109
1.0 / 1.5	2.140
2.0	2.610
2.5	3.141
3.0	3.673
4.0	4.776
6.0	6.695
8.0	8.695
10.0	10.695

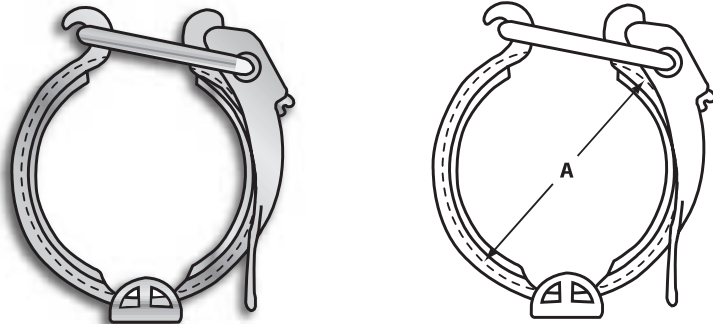

13MHLA

### 13MHLA - Adjustable Clamp

Size Range: 1.00 to 4.00 Tube O.D.

SIZE (TUBE O.D.) (inches)	A (inches)
1.0 / 1.5	2.140
2.0	2.610
2.5	3.141
3.0	3.673
4.0	4.776

## Bevel Seat Fittings: CLAMPS

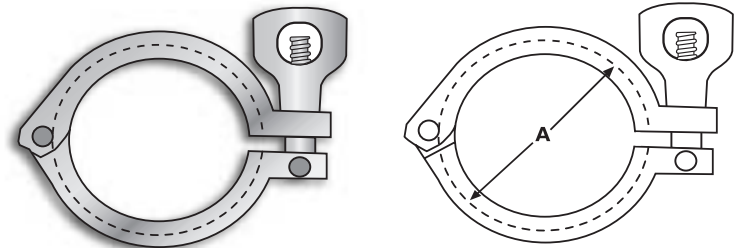

13IS

### 13IS - TI-LINE Heavy Duty Clamp

Size Range: .50 to 12.00 Tube O.D.

SIZE (TUBE O.D.) (inches)	A (inches)
0.50 / 0.75	
1.0 / 1.5	2.102
2.0	2.842
2.5	3.468
3.0	4.031
4.0	5.031
6.0	7.688

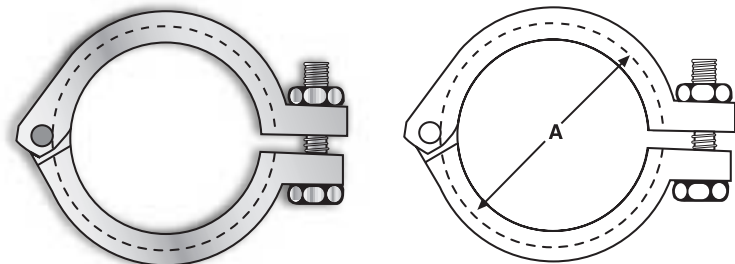

13ILB

### 13ILB - TI-LINE Bolted Clamp

Size Range: .50 to 12.00 Tube O.D.

SIZE (TUBE O.D.) (inches)	A (inches)
0.50 / 0.75	
1.0 / 1.5	1.06
2.0	1.41
2.5	1.75
3.0	2.03
4.0	2.50
6.0	

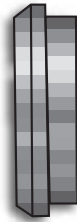

16A



**16A - Solid End Cap**

SIZE (inches)	A (inches)
1.0	1.312
1.5	1.843
2.0	2.375
2.5	2.906
3.0	3.437
4.0	4.500



13H

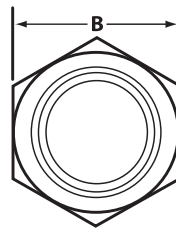

**13H - Hex Union Nut**

SIZE (inches)	A (inches)	B (inches)
1.0	0.906	1.812
1.5	0.968	2.406
2.0	1.062	3.000
2.5	1.187	3.593
3.0	1.281	4.187
4.0	1.500	5.437

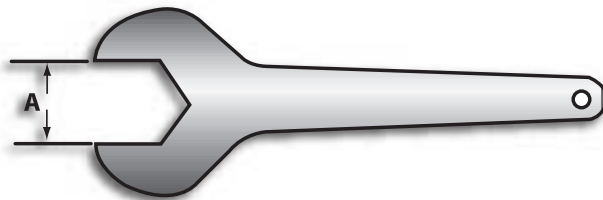

25H

**25H Aluminum Hex - Wrench Single End**

SIZE / A (inches)
1.0
1.5
2.0
2.5
3.0
4.0



## GASKETS & O-RINGS

Parker Performance Stainless supplies high-quality sanitary gaskets and o-rings for use with the Food, Beverage, Dairy and Pharmaceutical processing industries. These gaskets and o-rings are precision manufactured from specially formulated elastomer compounds, including Buna-N, EPDM, Viton®, Silicone and PTFE.

All gaskets and o-rings are certified to meet the specifications of FDA, 3-A Sanitary Standards and USP Class VI for pharmaceutical manufacturing.



## PRODUCT LISTING

### CLAMP GASKETS

<b>40MPU</b>	(BUNA)
<b>40MPUW</b>	(BUNA-White)
<b>40MPX</b>	(Silicone-White)
<b>40MPXC</b>	(Silicone-Clear)
<b>40MPG</b>	(PTFE)
<b>40MPE</b>	(EPDM)
<b>40MPSFY</b>	(SFY)
<b>40MPFU</b>	(BUNA-Flanged)
<b>40MPFE</b>	(EPDM-Flanged)
<b>40MPFX</b>	(Silicone-White-Flanged)
<b>40MPFXC</b>	(Silicone-Clear-Flanged)
<b>40MPSFY</b>	(SFY-Flanged)
<b>A40MPGR</b>	(PTFE-Envelope)

### ORIFICE GASKETS

<b>A80MPU</b>	(BUNA-Std 1/8" Orifice)
<b>A80MPE</b>	(EPDM-Std 1/8" Orifice)
<b>A80MPSFY</b>	(SFY-Std 1/8" Orifice)

### SCREEN GASKETS

<b>40MPSU</b>	(Std #10 Mesh*)
<b>40MPUP</b>	(Std #33 Perforated*)

\*Other Mesh Sizes Available

### BEVEL SEAT GASKETS

<b>40BSO</b>	(BUNA)
<b>40BSS-(TM)</b>	(PTFE)
<b>DHR(T)</b>	(PTFE-Medium)
<b>DH(XT)</b>	(PTFE-Extra Thin)
<b>40BSH(THD)</b>	(PTFE-Heavy Duty)
<b>40BSF</b>	(Flat)

### I-LINE GASKETS

<b>40IH</b>	(BUNA)
<b>40IE</b>	(EPDM)
<b>40IT</b>	(PTFE)
<b>40IV</b>	(SFY)

### JOHN PERRY GASKETS

<b>40JPU</b>	(BUNA)
--------------	--------

### Q-LINE GASKETS

<b>40QH</b>	(BUNA)
<b>40QT</b>	(PTFE)

### APC GASKETS

<b>101H</b>	(Gray)
<b>101HX</b>	(Black)

## GASKET MATERIAL REFERENCE CHART

Gasket material is selected based upon a number of factors [temperature, product type, pressure, etc.] The following guide is offered as a reference to assist in the selection of the appropriate elastomer for your application.

Original Physical Property Characteristics	Buna-N (U)	EPDM (E)	Fluoro-elastomer (SFY)	Silicone (X)	PTFE (G)
<b>Temperature Range</b>	-65 to 200°F	-60 to 300°F	-20 to 350°F	-40 to 450°F	-40 to 200°F
<b>Tensile Strength, psi</b>	1875	1650	1212	1340	—
<b>Elongation, %</b>	340	317	272	260	—
<b>Hardness, Shore A</b>	70	70	70	70	—
<b>Acid Resistance</b>	Good	Good/Excellent	Good/Excellent	Poor/Good	Good/Excellent
<b>Resistance to Fats/Oils</b>	Good/Excellent	Poor	Good/Excellent	Poor/Good	Excellent
<b>Alkali Resistance</b>	Fair/Good	Good/Excellent	Poor/Good	Poor/Fair	Excellent
<b>Abrasion Resistance</b>	Excellent	Good	Good/Excellent	Poor	Fair
<b>Compression Set Resistance</b>	Good	Fair	Good/Excellent	Good/Excellent	Cold Flows

# Miscellaneous Flow Components & Adapters

L2CP7-90° Inspection Elbow

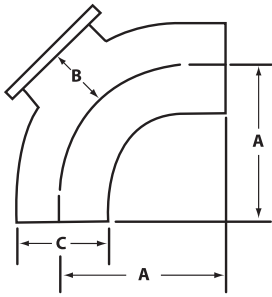

2CMP-31-90° Concentric Reducing Ell

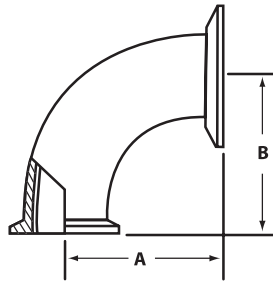

31 RMP-Reducing Ferrule-Concentric (3A)

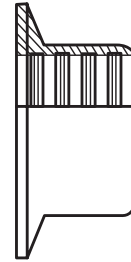

32 RMP-Reducing Ferrule-Concentric (3A)

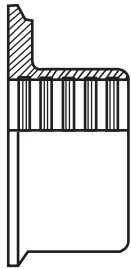

14MPHT - Tygon Hose Adapter

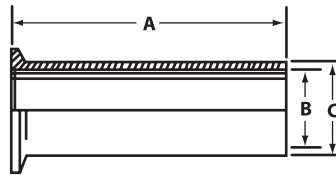

17MP-14 - Adapter (3A)

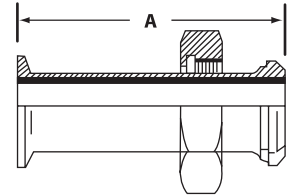

17MP-15 - Adapter (3A)

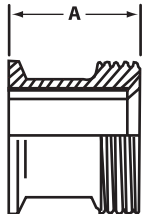

31 TMP-Adapter-Reducer-Concentric (3A)

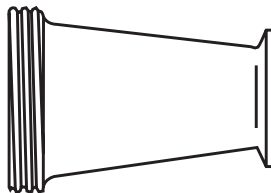

31 MPT-Adapter-Reducer-Concentric (3A)

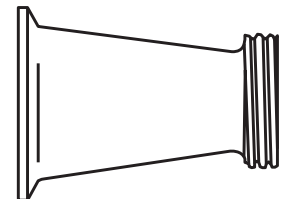

31 PMP-Reducing Ferrule-Concentric (3A)

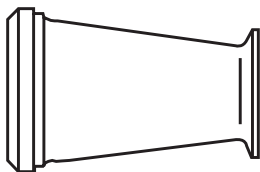

32 MMP-Adapter-Reducer-Concentric (3A)

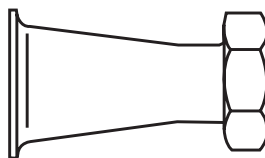

14PRF Short Weld Ferrule (3A)

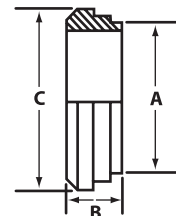

# Miscellaneous Flow Components & Adapters

**14R Plain Recessless Ferrule (3A)**

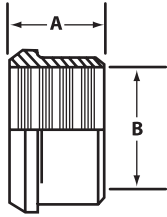

**L14A7 - Plain Tube Ferrule (3A)**

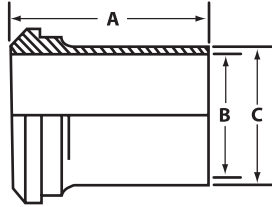

**14-W Plain Ferrule Tank Spud (Heavy) (3A)**

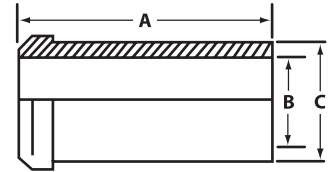

**15-W Threaded Ferrule Tank Spud (Heavy) (3A)**

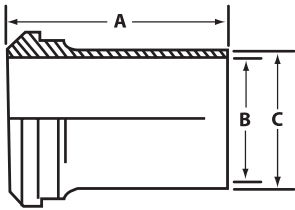

**L15A7 Threaded Tube Ferrule (3A)**

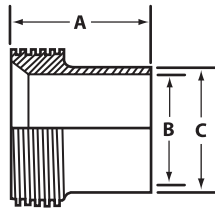

**15R-Threaded Recessless Ferrule (3A)**

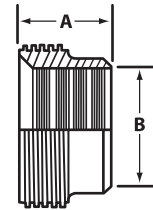

**15WL-Threaded Ferrule Tank Spud (Light) (3A)**

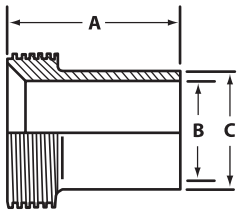

**14AHR Rubber Hose Adapter**

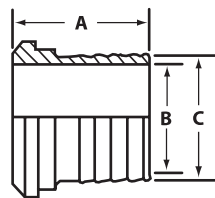

**14AHT-Tygon Hose Adapters**

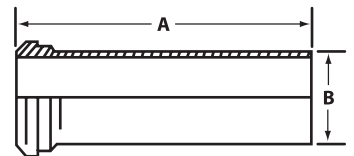

**15AHR Rubber Hose Adapter**

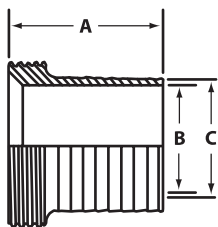

**15AHT-Tygon Hose Adapters**

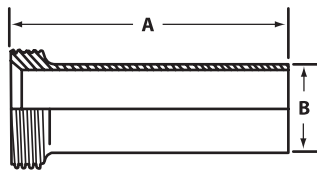

# Fittings for the Pharmaceutical and Biotech Industries



Parker will be launching a line of ASME BPE fittings for use within the Pharmaceutical and Biotech Industries. Fittings are offered in sizes from 1/2" through 6" in both butt-weld and clamp connections to ASME BPE standards.

I.D. finishes will be available in 25RA through 10RA. Special O.D. finishes will be available upon request. I.D. finishes may be provided in mechanical polish, or with Electropolishing per ASME BPE specifications.

## Material and Traceability

Parker offers fittings to BPE dimensions in 316L. All fittings are permanently marked with original heat numbers for full traceability back to the original stainless steel supplier. MTR information is provided with each fitting. All tubular materials meet ASTM A269 / A270 requirements and all machined components meet the requirements of ASTM A479.

## Heat Treatment

Parker fittings are solution annealed and quenched in a vacuum furnace. This treatment relieves stresses caused by cold forming operations used in the manufacturing process, thereby removing the potential for stress corrosion and improving the dimensional stability of fittings.

## Polish Options

Parker BPE fittings are manufactured with standard polished #7 O.D. with up to a 10 RA I.D. finish. Optional finishes and treatment available upon request.

## Fittings Marking

Each fitting is marked with the following:

- Parker logo and Parker BPE
- Heat Number
- Material Alloy
- ASME BPE
- Surface Designation per ASME BPE



## Inspection Procedures

All fittings are 100% visually inspected for surface finish imperfections as mentioned in table SF-3 in the ASME BPE 2002 specification.

All dimensional characteristics are inspected 100% to the tolerances listed in table DT-5 in the ASME BPE 2002 specification. As a part of rigorous inspection standard, heat number traceability is verified for accuracy and chemical composition, per table DT-3, before the fittings are packaged for shipment. Testing includes:

- Roundness
- Wall Thickness
- Squareness of Face
- Off Angle
- Off Plane
- Height

## Packaging

The ends are capped to prevent damage and contamination. All fittings are packaged in bags. All bags are labeled with Parker Part Number, Heat Number(s), ASME BPE, and the appropriate ASME BPE Surface Finish Designation for reorder, traceability and tracking purposes.

## Performance Stainless Product Family

Parker Performance Stainless offers a wide variety of sanitary flow components for use within the Food, Beverage, Dairy and Pharmaceutical processing industries. For additional information on any of the products shown below, contact your Parker distributor, or call 256-881-2040.



### BALL VALVES

3-Piece ball valves come standard in 316L and with PTFE cavity filler. Valves may be ordered with customized Parker Actuation for a variety of product applications.



### DIAPHRAGM VALVES

Parker will be launching a line of diaphragm valves for a variety of applications. Valves will feature class VI seat elastomers, and will offer full traceability with heat numbers.



### CHECK VALVES

Disk-style check valves are machined from heat-traced 316L stainless, and are available in both sanitary clamp and butt weld versions. EPDM gaskets are standard (Viton® and Silicone special order).



### BUTTERFLY VALVES

Butterfly valves will be available in both 4-position and 12-position handle configurations, and may be ordered with customized Parker Actuation. Several seat elastomers are available with platinum cured silicon standard.



### SANITARY GAUGES

Sanitary gauges meet 3A standards and are filled with FDA approved glycerine. Sanitary clamp connection is standard, and a variety of options is available for pressure and temperature ranges.



### SIGHT GLASSES

Sanitary sight glasses feature Pyrex glass and offer a visual inspection of product flow. Available in sanitary clamp and butt weld connections. Heat-traced 316L and EPDM gaskets are furnished as standard.



### GASKETS/O-RINGS

Parker will offer a wide variety of gaskets and o-rings in materials such as Buna, Silicon, PTFE, EPDM and more. Speciality items such as screen gaskets will also be available. Gaskets meet 3A and other regulatory standards.



### INLINE STRAINER

Inline Strainers are manufactured for easy interchange with other brands, and feature a variety of filter and screen options for a wide range of process applications.



### SANITARY TUBING

Sanitary tubing is manufactured in accordance with A-270, A-269, A-249 or BPE standards. Tubing is available in a variety of polish configurations.



### SANITARY FITTINGS

Sanitary fittings are available in 304SS or heat-traced 316L in both polished and tumble finishes. Call for special finish options or for details on BPE-Compliant fittings for your all processing applications.

### Clamp Service Rating Chart in PSI

Size Tube OD	1/2" & 3/4"	1" & 1-1/2"	2"	2-1/2"	3"	4"	6"
<b>13MHLA - Screw tightened to maximum</b>							
at 70°F	—	150	150	150	150	150	—
at 250°F	—	125	125	125	125	125	—
<b>13HHM - Wing nut tightened to 25 in. lb. of torque</b>							
at 70°F	—	500	450	400	350	350	150
at 250°F	—	300	300	200	195	195	75
<b>13MHP - Bolts tightened to 20 ft. lb. of torque</b>							
at 70°F	—	1500	1000	1000	1000	1000	300
at 250°F	—	1200	800	800	800	800	200
<b>A13MHM - Wing nut tightened to 25 in. lb. of torque</b>							
at 70°F	—	500	450	400	350	350	150
at 250°F	—	300	250	200	175	175	75

\*PSI ratings based on hydrostatic test using standard gaskets molded from Buna-N. Ratings assume proper installation of ferrules, joint assembly and the absence of any shock pressure. Please contact Parker Hannifin for ratings at higher temperatures or utilizing other materials. For temperatures above 250° F, only 13MHP clamps are recommended.



13MHLA

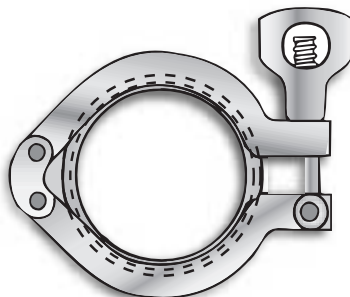

13HHM

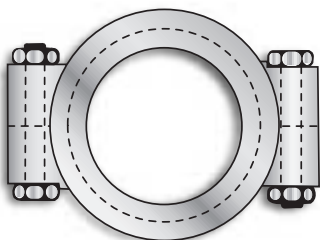

13MHP

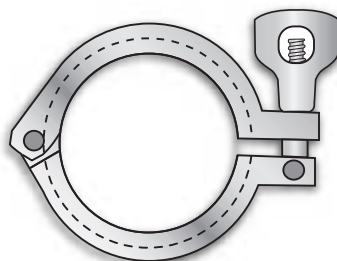

A13MHM

### Clamp Gasket Materials Reference Chart

Original Physical Property Characteristics	Buna-N (U)	EPDM (E)	Fluoro-elastomer (SFY)	Silicone (X)	PTFE (G)
Temperature Range	-65 to 200°F	-60 to 300°F	-20 to 350°F	-40 to 450°F	-40 to 200°F
Tensile Strength, psi	1875	1650	1212	1340	—
Elongation, %	340	317	272	260	—
Hardness, Shore A	70	70	70	70	—
Acid Resistance	Good	Good/Excellent	Good/Excellent	Poor/Good	Good/Excellent
Resistance to Fats/Oils	Good/Excellent	Poor	Good/Excellent	Poor/Good	Excellent
Alkali Resistance	Fair/Good	Good/Excellent	Poor/Good	Poor/Fair	Excellent
Abrasion Resistance	Excellent	Good	Good/Excellent	Poor	Fair
Compression Set Resistance	Good	Fair	Good/Excellent	Good/Excellent	Cold Flows

### Dimensions of Clamp Connections for OD-Tubing

OD Outer Diameter (inches)	ID Inner Diameter (inches)	Wall Thickness (inches/gauge)	A Ferrule Face (inches)
1/2	0.37	0.065 / 16ga.	0.984
3/4	0.62	0.065 / 16ga.	0.984
1	0.87	0.065 / 16ga.	1.984
1-1/2	1.37	0.065 / 16ga.	1.984
2	1.87	0.065 / 16ga.	2.516
2-1/2	2.37	0.065 / 16ga.	3.047
3	2.87	0.065 / 16ga.	3.579
4	3.87	0.083 / 14ga.	4.682

### Surface Finish Reference Chart

Polishing Code	Inside Diameter [ID] / Product Contact Surface			Polish Method	OD / Product Noncontact Surface
	Maximum Surface Roughness (RA)				
	Microrinches (μ-inch)	Micrometers (μm)	ASME BPE Finish Code		
1				Unpolished	Unpolished
3	32	0.8	—	Mechanical Polished	Unpolished
7	32	0.8	—	Mechanical Polished	Polished to Ra, 32 μ-inch/0.8um
PC	20	0.5	SFF1	Mechanical Polished	Unpolished
PD	15	0.4	SFF4	Mechanical Polished and Electropolished	Unpolished
PL	20	0.5	SFF1	Mechanical Polished	Polished to Ra, 32 μ-inch/0.8um
PM	15	0.4	SFF4	Mechanical Polished and Electropolished	Polished to Ra, 32 μ-inch/0.8um



## Offer of Sale

The items described in this document and other documents or descriptions provided by Parker Hannifin Corporation, its subsidiaries and its authorized distributors are hereby offered for sale at prices to be established by Parker Hannifin Corporation, its subsidiaries and its authorized distributors. This offer and its acceptance by any customer ("Buyer") shall be governed by all of the following Terms and Conditions. Buyer's order for any such items, when communicated to Parker Hannifin Corporation, its subsidiary or an authorized distributor ("Seller") verbally or in writing, shall constitute acceptance of this offer.

**1. Terms and Conditions of Sale:** All descriptions, quotations, proposals, offers, acknowledgments, acceptances and sales of Seller's products are subject to and shall be governed exclusively by the terms and conditions stated herein. Buyer's acceptance of any offer to sell is limited to these terms and conditions. Any terms or conditions in addition to, or inconsistent with those stated herein, proposed by Buyer in any acceptance of an offer by Seller, are hereby objected to. No such additional, different or inconsistent terms and conditions shall become part of the contract between Buyer and Seller unless expressly accepted in writing by Seller. Seller's acceptance of any offer to purchase by Buyer is expressly conditional upon Buyer's assent to all the terms and conditions stated herein, including any terms in addition to, or inconsistent with those contained in Buyer's offer. Acceptance of Seller's products shall in all events constitute such assent.

**2. Payment:** Payment shall be made by Buyer net 30 days from the date of delivery of the items purchased hereunder. Amounts not timely paid shall bear interest at the maximum rate permitted by law for each month or portion thereof that the Buyer is late in making payment. Any claims by Buyer for omissions or shortages in a shipment shall be waived unless Seller receives notice thereof within 30 days after Buyer's receipt of the shipment.

**3. Delivery:** Unless otherwise provided on the face hereof, delivery shall be made F.O.B. Seller's plant. Regardless of the method of delivery, however, risk of loss shall pass to Buyer upon Seller's delivery to a carrier. Any delivery dates shown are approximate only and Seller shall have no liability for any delays in delivery.

**4. Warranty:** Seller warrants that the items sold hereunder shall be free from defects in material or workmanship for a period of 18 months from date of shipment from Parker Hannifin Corporation. **THIS WARRANTY COMPRISES THE SOLE AND ENTIRE WARRANTY PERTAINING TO ITEMS PROVIDED HEREUNDER. SELLER MAKES NO OTHER WARRANTY, GUARANTEE, OR REPRESENTATION OF ANY KIND WHATSOEVER. ALL OTHER WARRANTIES, INCLUDING BUT NOT LIMITED TO, MERCHANTABILITY AND FITNESS FOR PURPOSE, WHETHER EXPRESS, IMPLIED, OR ARISING BY OPERATION OF LAW, TRADE USAGE, OR COURSE OF DEALING ARE HEREBY DISCLAIMED. NOTWITHSTANDING THE FOREGOING, THERE ARE NO WARRANTIES WHATSOEVER ON ITEMS BUILT OR ACQUIRED WHOLLY OR PARTIALLY, TO BUYER'S DESIGNS OR SPECIFICATIONS.**

**5. Limitation Of Remedy: SELLER'S LIABILITY ARISING FROM OR IN ANY WAY CONNECTED WITH THE ITEMS SOLD OR THIS CONTRACT SHALL BE LIMITED EXCLUSIVELY TO REPAIR OR REPLACEMENT OF THE ITEMS SOLD OR REFUND OF THE PURCHASE PRICE PAID BY BUYER, AT SELLER'S SOLE OPTION. IN NO EVENT SHALL SELLER BE LIABLE FOR ANY INCIDENTAL, CONSEQUENTIAL OR SPECIAL DAMAGES OF ANY KIND OR NATURE WHATSOEVER, INCLUDING BUT NOT LIMITED TO LOST PROFITS ARISING FROM OR IN ANY WAY CONNECTED WITH THIS AGREEMENT OR ITEMS SOLD HEREUNDER, WHETHER ALLEGED TO ARISE FROM BREACH OF CONTRACT, EXPRESS OR IMPLIED WARRANTY, OR IN TORT, INCLUDING WITHOUT LIMITATION, NEGLIGENCE, FAILURE TO WARN OR STRICT LIABILITY.**

**6. Changes, Reschedules and Cancellations:** Buyer may request to modify the designs or specifications for the items sold hereunder as well as the quantities and delivery dates thereof, or may request to cancel all or part of this order, however, no such requested modification or cancellation shall become part of the contract between Buyer and Seller unless accepted by Seller in a written amendment to this Agreement. Acceptance of any such requested modification or cancellation shall be at Seller's discretion, and shall be upon such terms and conditions as Seller may require.

**7. Special Tooling:** A tooling charge may be imposed for any special tooling, including without limitation, dies, fixtures, molds and patterns, acquired to manufacture items sold pursuant to this contract. Such special tooling shall be and remain Seller's property notwithstanding payment of any charges by Buyer. In no event will Buyer acquire any interest in apparatus belonging to Seller which is utilized in the notwithstanding any charges paid by Buyer. Unless otherwise agreed, Seller shall have the right to alter, discard or otherwise dispose of any special tooling or other property in its sole discretion at any time.

**8. Buyer's Property:** Any designs, tools, patterns, materials, drawings, confidential information or equipment furnished by Buyer or any other items which become Buyer's property, may be considered obsolete and may be destroyed by Seller after two (2) consecutive years have elapsed without Buyer placing an order for the items which are manufactured using such property, Seller shall not be responsible for any loss or damage to such property while it is in Seller's possession or control.

**9. Taxes:** Unless otherwise indicated on the face hereof, all prices and charges are exclusive of excise, sales, use, property, occupational or like taxes which may be imposed by any taxing authority upon the manufacture, sale or delivery of the items sold hereunder. If any such taxes must be paid by Seller or if Seller is liable for the collection of such tax, the amount thereof shall be in addition to the amounts for the items sold. Buyer agrees to pay all such taxes or to reimburse Seller therefore upon receipt of its invoice. If Buyer claims exemption from any sales, use or other tax imposed by any taxing authority, Buyer shall save Seller harmless from and against any such tax, together with any interest or penalties thereon which may be assessed if the items are held to be taxable.

**10. Indemnity For Infringement of Intellectual Property Rights:** Seller shall have no liability for infringement of any patents, trademarks, copyrights, trade dress, trade secrets or similar rights except as provided in this Part 10. Seller will defend and indemnify Buyer against allegations of infringement of U.S. Patents, U.S. Trademarks, copyrights, trade dress and trade secrets (hereinafter 'Intellectual Property Rights'). Seller will defend at its expense and will pay the cost of any settlement or damages awarded in an action brought against Buyer based on an allegation that an item sold pursuant to this contract infringes the Intellectual Property Rights of a third party. Seller's obligation to defend and indemnify Buyer is contingent on Buyer notifying Seller within ten (10) days after Buyer becomes aware of such allegations of infringement, and Seller having sole control over the defense of any allegations or actions including all negotiations for settlement or compromise. If an item sold hereunder is subject to a claim that it infringes the Intellectual Property Rights of a third party, Seller may, at its sole expense and option, procure for Buyer the right to continue using said item, replace or modify said item so as to make it noninfringing, or offer to accept return of said item and return the purchase price less a reasonable allowance for depreciation. Notwithstanding the foregoing, Seller shall have no liability for claims of infringement based on information provided by Buyer, or directed to items delivered hereunder for which the designs are specified in whole or part by Buyer, or infringements resulting from the modification, combination or use in a system of any item sold hereunder. The foregoing provisions of this Part 10 shall constitute Seller's sole and exclusive liability and Buyer's sole and exclusive remedy for infringement of Intellectual Property Rights. If a claim is based on information provided by Buyer or if the design for an item delivered hereunder is specified in whole or in part by Buyer, Buyer shall defend and indemnify Seller for all costs, expenses or judgments resulting from any claim that such item infringes any patent, trademark, copyright, trade dress, trade secret or any similar right.

**11. Force Majeure:** Seller does not assume the risk of and shall not be liable for delay or failure to perform any of Seller's obligations by reason of circumstances beyond the reasonable control of Seller (hereinafter 'Events of Force Majeure'). Events of Force Majeure shall include without limitation, accidents, acts of God, strikes or labor disputes, acts, laws, rules or regulations of any government or government agency, fires, floods, delays or failures in delivery of carriers or suppliers, shortages of materials and any other cause beyond Seller's control.

**12. Entire Agreement/Governing Law:** The terms and conditions set forth herein, together with any amendments, modifications and any different terms or conditions expressly accepted by Seller in writing, shall constitute the entire Agreement concerning the items sold, and there are no oral or other representations or agreements which pertain thereto. This Agreement shall be governed in all respects by the law of the State of Ohio. No actions arising out of the sale of the items sold hereunder or this Agreement may be brought by either party more than two (2) years after the cause of action accrues.

9/91-P





**Parker Hannifin Corporation**  
 6035 Parkland Blvd.  
 Cleveland, Ohio 44124-4141  
 Telephone: (216) 896-3000  
 Fax: (216) 896-4000  
 www.parker.com

## **Parker Hannifin Corporation**

### **About Parker Hannifin Corporation**

Parker Hannifin is a leading global motion-control company dedicated to delivering premier customer service. A Fortune 500 corporation listed on the New York Stock Exchange (PH), our components and systems comprise over 1,400 product lines that control motion in some 1,000 industrial and aerospace markets. Parker is the only manufacturer to offer its customers a choice of hydraulic, pneumatic, and electromechanical motion-control solutions. Our company has the largest distribution network in its field, with over 7,500 distributors serving nearly 400,000 customers worldwide.

### **Parker's Charter**

To be a leading worldwide manufacturer of components and systems for the builders and users of durable goods. More specifically, we will design, market and manufacture products controlling motion, flow and pressure. We will achieve profitable growth through premier customer service.

### **Product Information**

North American customers seeking product information, the location of a nearby distributor, or repair services will receive prompt attention by calling the Parker Product Information Center at our toll-free number: 1-800-C-PARKER (1-800-272-7537). In Europe, call 00800-C-PARKER-H (00800-2727-5374).

**The Aerospace Group** is a leader in the development, design, manufacture and servicing of control systems and components for aerospace and related high-technology markets, while achieving growth through premier customer service.



**The Climate & Industrial Controls Group** designs, manufactures and markets system-control and fluid-handling components and systems to refrigeration, air-conditioning and industrial customers worldwide.



**The Fluid Connectors Group** designs, manufactures and markets rigid and flexible connectors, and associated products used in pneumatic and fluid systems.



**The Seal Group** designs, manufactures and distributes industrial and commercial sealing devices and related products by providing superior quality and total customer satisfaction.



**The Hydraulics Group** designs, produces and markets a full spectrum of hydraulic components and systems to builders and users of industrial and mobile machinery and equipment.



**The Filtration Group** designs, manufactures and markets quality filtration and clarification products, providing customers with the best value, quality, technical support, and global availability.



**The Automation Group** is a leading supplier of pneumatic and electromechanical components and systems to automation customers worldwide.



**The Instrumentation Group** is a global leader in the design, manufacture and distribution of high-quality critical flow components for worldwide process instrumentation, ultra-high-purity, medical and analytical applications.



---

*Performance*  
*Stainless* 

anything   
Possible.™

**Parker Hannifin Corporation**  
Instrumentation Products Division  
1500 A Cleaner Way  
Huntsville, AL 35803  
Phone: (256) 881-2040  
Fax: (256) 881-5072  
[www.parker.com/ipdus](http://www.parker.com/ipdus)